

DESCH Lutex® CLUTCH/BRAKE COMBINATION

Type LKB - pneumatically actuated



Lutex® clutch/brake combination LKB



Application of area

The pneumatically actuated Lutex® LKB is a dry running single plate combined clutch/brake (it is referred to the following text as the C-B-C). Originally developed for use on presses and shearing machines it is particularly suitable for applications where medium and large inertias are to be accelerated or decelerated. The heat resistant properties of the friction surfaces enables the Lutex® C-B-C to achieve the high operating cycle required by presses. Its compact construction allows the C-B-C to be mounted in a very small space between the machine frame and the flywheel. The C-B-C conforms to the safety requirements of the EN 692: 2005+A1:2009.

Function

The brake disc is mounted on the press/machine frame whilst the clutch disc is mounted on the flywheel. The piston is mounted on the hub and is free to move axially between the hub and the cylinder. In the depressurized mode compression springs keep the brake disc in contact with the cylinder. The brake is on. As air is flowing into the cylinder the spring tension is overcome and the brake begins to open, the increase in air pressure engages the clutch.

The friction discs are available with either 12-point or 2-point mounting (see table on page 3). In the 2-point system the mounting points can be either long or short depending upon the machine frame requirements.

Benefits of the Lutex® clutch/brake combination (C-B-C)

- The LKB series covers most of the standard mounting requirements
- Low-maintenance, safe, reliable
- Low moment of inertia
- Large shaft bore
- High heat resistance
- Low air consumption
- High frequency of operation
- High engagement repeatability
- Heavy duty friction linings with long life time
- 2-point mounting system with plastic collar for noise and vibration absorption
- Quick and easy replacement of the friction discs
- Several methods of mounting the friction discs
- Wide range of brake and clutch settings
- Mechanical wear adjustment (on sizes 30 to 75)
- Certificate of conformity to safety regulations
- Use of clamping elements (as an option)

Technical data

Size		05	10	15	20	25	30	35	40	45	50	55	60	65	70	75
Clutch ¹⁾	T_u ¹⁾ Nm	250	400	760	1500	3000	5700	7200	9000	13000	17500	23500	37000	56000	80000	115000
Brake ³⁾	T_s ²⁾ Nm	140	225	430	850	1700	3200	4100	5100	7400	10000	13400	21000	32000	46000	65000
Weight kg	LKB	5,3	7,0	12,6	23,6	45,1	87,2	109	133,9	179	271	367	603	764	1048	1577
	LKBZ	5,7	7,6	14,2	25,6	49,0	95,8	118	143,8	194	294	395	649	811	1104	1662
	LKBZU	5,8	7,7	14,4	25,7	49,7	96,3	119	144,5	196	298	399	657	819	1115	1678
	LKBBZ	5,4	7,3	13,4	24,6	47,1	91,5	114	138,8	187	283	381	626	788	1076	1620
	LKBBZU	5,6	7,4	13,6	24,4	47,8	92,0	114	139,6	189	286	385	634	796	1087	1636
J inside	kgm ² all types	0,014	0,024	0,064	0,202	0,59	1,61	2,31	3,33	5,41	10,42	17,09	40,48	57,93	98,79	191,93
J outside	LKB/LKBBZ/ LKBBZU	0,004	0,006	0,017	0,047	0,16	0,58	0,81	1,14	1,88	3,78	6,84	13,10	14,07	25,72	43,69
	LKBZ/LKBZU/LKBKZ	0,007	0,010	0,035	0,074	0,25	0,90	1,18	1,62	2,56	5,51	9,07	19,04	19,04	36,76	63,07
Cylinder volume	new ⁴⁾	0,04	0,05	0,08	0,19	0,3	0,5	0,6	0,8	1,2	1,7	2	2,9	4,1	5,1	8,8
	worn ⁴⁾	0,06	0,09	0,15	0,31	0,6	0,9	1,2	1,5	2,3	3,4	4	6,3	10	12,6	18,4
Max. speed	rpm ⁻¹ ⁵⁾	2800	2800	2500	1800	1400	1200	1100	1000	900	800	700	600	600	550	500
Linear dimensions in mm	A ISO JS 10 ⁶⁾	230	250	315	390	495	610	645	695	770	880	970	1140	1140	1300	1465
	A1 ISO JS 10 ⁶⁾	305	325	410	490	635	790	830	885	990	1135	1235	1450	1450	1645	1855
	B	262	282	360	435	560	695	730	780	870	1000	1090	1280	1280	1460	1625
	B ₁	337	357	442	522	680	855	895	950	1075	1235	1335	1570	1570	1790	1995
	c	9	11	12	15	19	22	27	27	28	35	36	40	40	50	50
	c ₁	25	20	35	35	45	50	50	50	60	70	70	90	90	90	110
	c ₂	25	20	20	20	35	45	45	45	50	60	60	70	70	70	90
	E	11	11	16	16	20	27	27	27	29,5	38,5	38,5	44,5	44,5	44,5	50,5
	E ₁	11	11	11	11	16	20	20	20	27	29,5	29,5	38,5	38,5	38,5	45,5
	H	20	20	25	25	25	35	35	35	35	45	45	45	45	45	45
	H ₁	20	20	20	20	25	25	25	25	35	35	35	45	45	45	45
	G	17	18	20	22	29	32	37,5	38	42,5	48	55	65	70	75	90
	G ₁	11	12	15	18	22,5	26,5	29,5	29,5	31	35,5	38,5	45	49	54	61
	G ₂	17	21	23	30,5	36,5	42,5	48	49,5	56	64,5	72	85	141	144	180
	G ₃	56	64	73	90	110	135	150	155	170	195	215	260	320	350	410
	L	50	58	65	82	100	125	140	145	160	185	205	250	310	340	400
	L ₁	55	62	78	95	112	135	148	155	165	186	202	248	257	288	325
	L ₂	26,5	30	38	50	52	66	75	82	83	98	110	145	148	172	170
	L ₃	16	20	20	25	35	40	45	45	50	60	70	70	70	90	90
	L ₄	55,5	58	72	86	104	127	140	145	155	176	192	233	242	273	308
L ₅	13	14	17	23	21,5	31,5	37,5	47	42	52,5	61,5	87,5	84	103	92	
s	3	3	4	4	5	5	5	5	5	5	5	5	5	5	5	
t	2	2	2	3	3	3	3	3	3	5	5	5	5	5	5	
o	7	7	10	13	13	13	13	13	13	15	15	15	20	20	22	
D _a	196	220	275	347	435	535	570	620	680	775	865	1000	1000	1150	1290	
D ₁	80	85	105	125	155	175	185	190	210	245	280	320	320	365	420	
D ₂	166	188	235	304	380	465	497	543	593	675	755	885	885	1005	1140	
D ₅ ISO k6 ⁶⁾	14	14	22	22	30	40	40	40	45	55	55	65	65	65	80	
D ₆ ISO k6 ⁶⁾	14	14	14	14	22	30	30	30	40	45	45	55	55	55	65	
d	7	8	8,5	12	14	14	18	18	18	20	20	24	28	30	32	
d ₁ ⁷⁾	M5	M5	M6	M8	M10	M14	M14	M14	M14	M16	M20	M24	M24	M24	M30	
d ₄	M4 x 12	M4 x 12	M5 x 16	M5 x 16	M5 x 16	M6 x 20	M6 x 20	M6 x 20	M6 x 20	M8 x 25	M8 x 25	M8 x 25	M8 x 25	M8 x 25	M8 x 25	
d ₇	M4 x 12	M4 x 12	M4 x 12	M4 x 12	M5 x 16	M5 x 16	M5 x 16	M5 x 16	M6 x 20	M6 x 20	M6 x 20	M8 x 25	M8 x 25	M8 x 25	M8 x 25	
K JS 10 ⁶⁾	182	205	255	325	408	500	536	584	640	725	810	945	945	1080	1220	
Z - 0,1	10	10	12	15	18	25	25	25	30	35	40	40	40	50	50	
D _{max} (ISO H7) ⁸⁾	35	40	52	70	90	110	115	125	140	160	180	210	210	240	270	
keyway DIN 6885																
D _{min} (ISO H7)	20	25	35	40	45	45	60	60	70	70	80	90	90	130	165	

In the range of max. speed (ca. $0,7 \times n_{max}$) we recommend dynamical balancing.

1) T_u = static torque at $p = 6$ bar

2) T_s = dynamic torque

3) Alteration of clutch/brake torque relation possible. Details on request

4) Type with reduced cylinder volume on request

5) Not permitted for operation with single strokes

6) Tolerances for connecting parts

7) Self-locking screws

8) Clamping elements on request

Types

Type	Mounting of the friction disc					
	brake disc			clutch disc		
	12 - point	2 - point		12 - point	2 - point	
	short strap	long strap	short strap	long strap	long strap	
LKB	•			•		
LKBZ		•			•	
LKBBZ		•		•		
LKBZU			•		•	
LKBBZU			•	•		

Type LKB

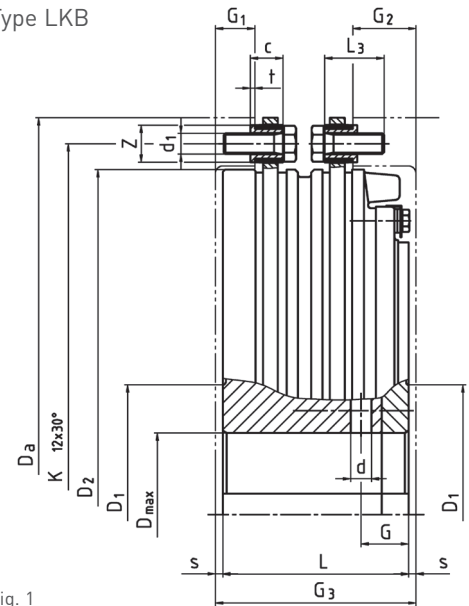

Fig. 1

Type LKBZ

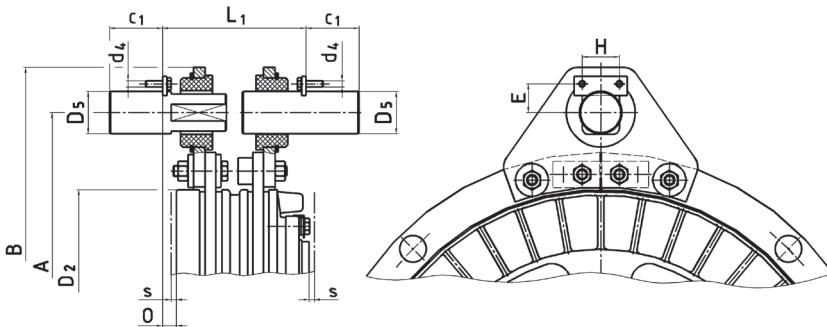

Fig. 2

Type LKBBZ

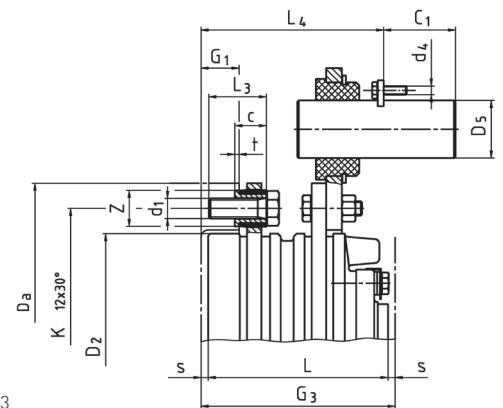

Fig. 3

Type LKBZU

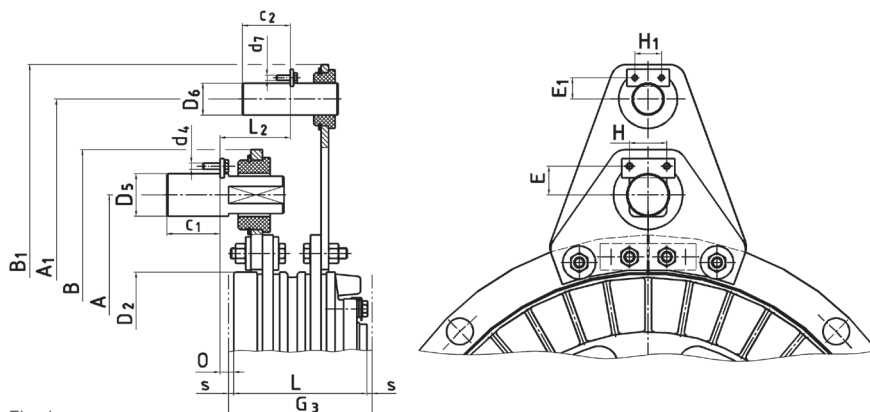

Fig. 4

Type LKBBZU

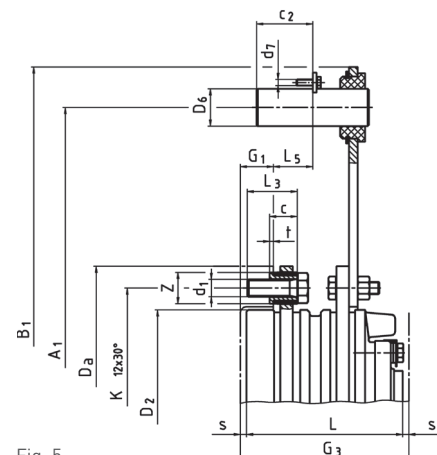

Fig. 5

Air supply

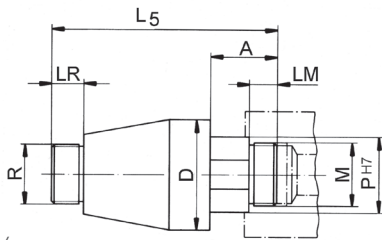
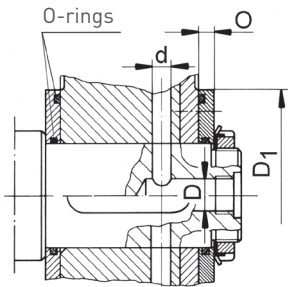

Fig. 6

Direct connection of the press safety valve or the electromagnetic valve with rotating air supply is possible. A rotary air supply system for higher speed is available as an option.

Rotor size R	G ^{3/8}	G ^{1/2}	G ^{3/4}	G1	G1 ^{1/4}	G1 ^{1/2}	G2
Part number	653	654	655	656	657	658	659
Max. speed [rpm]	2800	2500	1400	1200	800	700	600
A	26,5	35,5	37,5	37,5	42	42	51
LM	14	15	15	15	22	22	25
LR	12	12	16	18	20	22	25
D	38	55	65	65	88	88	110
M	M 16	M 35x1,5	M 35x1,5	M 35x1,5	M 50x1,5	M 50x1,5	M 65x1,5
p H7	20	40	40	40	60	60	70
L5	81,5	115,5	123,5	125,5	149	151	214
Suitable for Lutex® LKB-...	05-10	10-20	20-30	25-40	45-60	55-65	65-75

Shaft sealing



Cover seal is only available with a closed keyway

Fig. 7

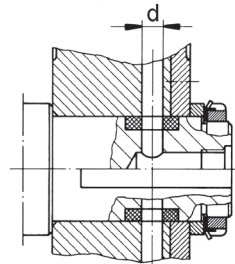

Grooved shaft seal is available with an open keyway

Fig. 8

The diameter "D" of the shaft bore should be approximately 1.4 times that of the air supply bore, diameter "d".

Examples of installation

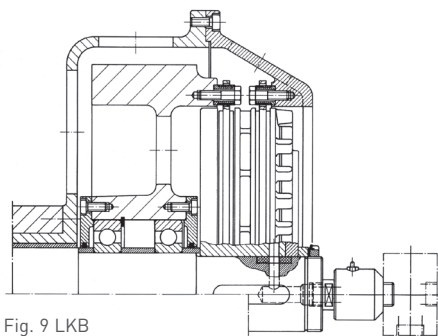

Fig. 9 LKB

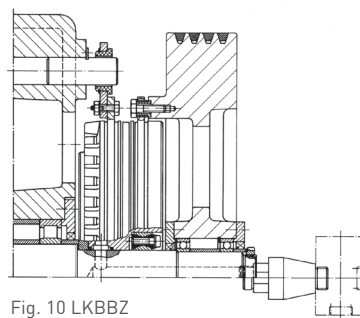

Fig. 10 LKBBZ

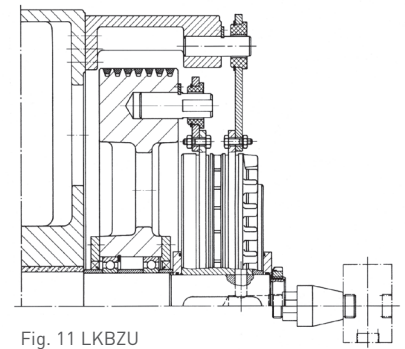

Fig. 11 LKBZU

Other products for press drives

- Lutex® LS - Pneumatically actuated clutch/brake combination with high torque at small dimensions
- Lutex® HKB, HKBT - Hydraulically actuated clutch/brake combination: separate clutch - separate brake
- DESCH Complete Press Drive KA - Complete press drives. (either hydraulically or pneumatically operated) together with planetary gearbox and flywheel
- DESCH Complete Press Drive KAS - Complete press drives with hydraulically actuated clutch and brake, with planetary gearbox, flywheel and additionally with an engageable gear step
- DESCH Complete Press Drive KAE - Complete press drives with planetary gearbox, pneumatically or hydraulically actuated clutch/brake combination and a flywheel. KAE with integrated torque motor inside of the flywheel
- DESCH Servox® type series - One- or two-stage planetary gearbox with hydraulically released brake and with adaptor for common torque motors, also available with spur gear for up to 4 motors
- Further components - Quick exhaust module, crankshafts, flywheels, pulleys, s and accessories
- Customised solutions on request!

CONTACT

DESCH Antriebstechnik GmbH & Co. KG
Postbox 1440
59753 Arnsberg/Germany
Kleinbahnstraße 21
59759 Arnsberg/Germany
T +49 2932 300 153
F +49 2932 300 899
sales@desch.com
www.desch.com



DESCH Canada Ltd.
240 Shearson Crescent
Cambridge
Ontario
Canada N 1T 1J6
T +1800 2631866
+1519 6214560
F +1519 6231169
desch.canada@desch.com

DESCH USA Inc.
3501 Embassy
Parkway
Suite 101
Akron
Ohio 44333
T +1 330 937 9030
F +1 330 937 9031
sales_usa@desch.com

DESCH Service Center
USA LP
4940 Merrifield Rd
Dallas
Texas 75236
T +1 469 221 2190
F +1 469 221 2191
desch.dallas@desch.com

DESCH Italy
Drive Technology
Ufficio di rappresentanza
in Italia
Via Cavriana, 3
20134 Milano/Italy
T +39 02 7391 280
F +39 02 7391 410
desch.italia@desch.com

DESCH China
Machinery (Pinghu) Co., Ltd.
No. 1680 Xingping 1 Road, Build. 3
Pinghu Economic Technological
Development Zone
314200 Zhejiang P. R. China
T +86 573 8557 8988
F +86 573 8557 8989
desch.china@desch.com

DESCH do Brasil
Power Transmission S.A.
Rdv Edgar Máximo
Zambotto, s/n km 54
Campo Limpo Paulista, SP
CEP: 13.231-700
T +55 11 4039 8240
F +55 11 4039 8222
desch.brasilien@desch.com