

## PM type Stepping Motors MSEU series

### MSEU series



### Applications

smartphone

### Characteristics

- The motor has an optimized magnetic circuit design for smartphones and mobile devices.
- The torque of this motor is equivalent to that of a motor one size larger, making it suitable for space saving.

### Dimensions / Torque characteristic

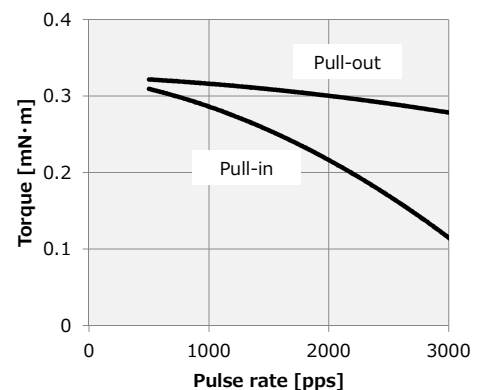
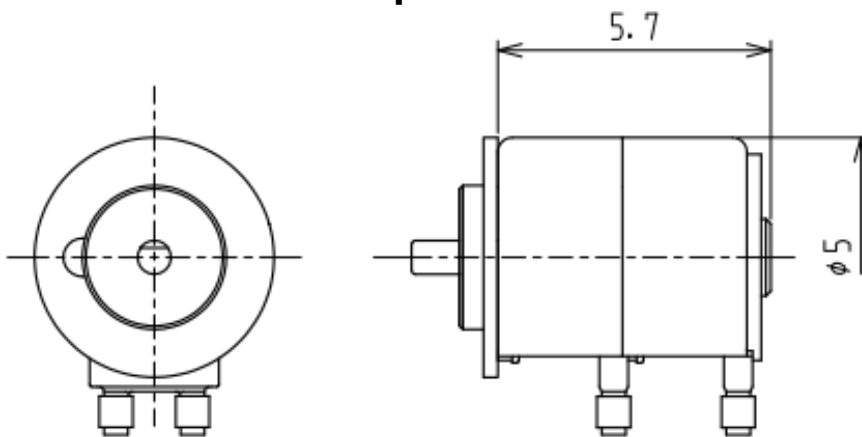

Characteristic data is based on standard specifications

## NIDEC SANKYO CORPORATION

For additional information, please contact our sales.

### Tokyo Office

Nidec Tokyo Bldg., 1-20-13 Osaki, Shinagawa-ku, Tokyo 141-0032, Japan Tel:(81)3-5740-3000