

New release!

SX-8-360

超高速精密自动冲床
(加压能力8吨)

Ultra high speed high precision
automatic press(Capacity 8t)

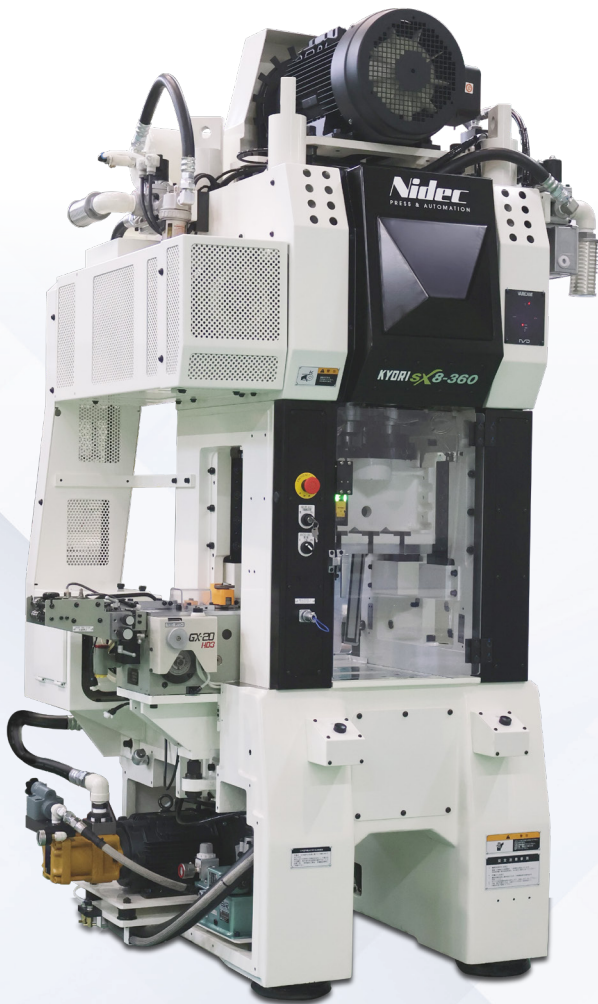

- 连杆冲床

世界最快速3000spm

龙门式连杆冲床
行程长7mm

- 高刚性高精度

10吨以下的小型唯一的真正龙门式连杆冲床

- 节省空间

Experience the world's fastest link press at 3000 spm.

This compact yet powerful straight-side press (7mm stroke) delivers exceptional rigidity and accuracy.

规格 / Specifications

		SX-8-360
结构	Mechanism	固定行程长度连杆冲床 Fixed stroke link motion press
滑块尺寸	Slide (W x D)	360 × 280
工作台尺寸	Bolster (W x D)	360 × 360
滑块材质	Slide material	高刚性铝合金 High rigidity aluminium alloy
行程长度	Stroke length	6 - 12 mm
最高转速	Max. speed	Max. 3000 spm
闭模高度	Die height	220 mm
闭模高度调整量	Die height adjustment	30 mm
滑块铝板	Slide sub-plate	25 mm
工作台厚度	Bolster thickness	100 mm
最大上模重量	Max. upper die weight	30 kg

外观图 / General View

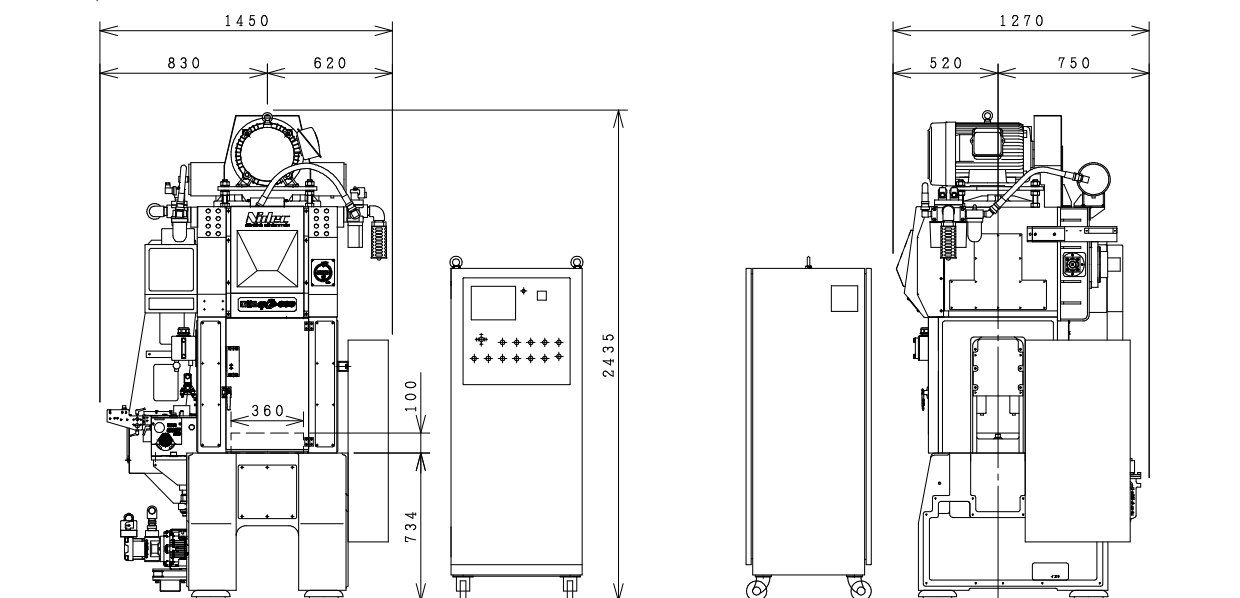

滑块·工作台 / Slide, Bolster

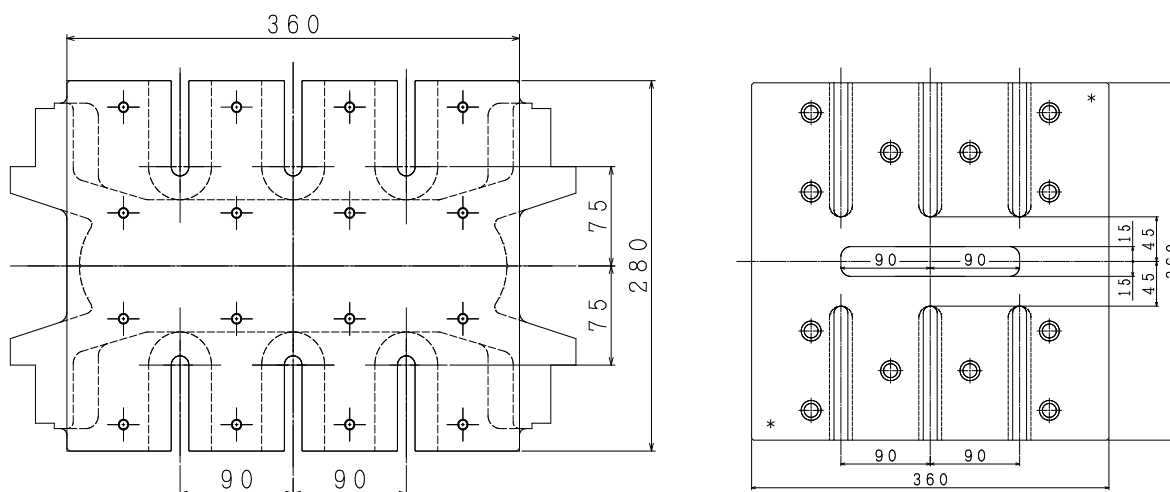

※规格、尺寸等或随改良更新，恕不提前告知。

照片不是标准规格的。记载的数值会根据使用条件等而变化，请谅解。

上述规格全部为标准规格，特别规格时请另行咨询。

Specifications and designs are subject to change due to future modifications without prior notice.

The machines shown in the photograph may not represent the standard equipment.

The specifications may be different depending on operation conditions.