



RINGCONE[®] **Adjustable Speed Drive**



200B to 7500

Instruction Manual

Contents

Safety Precautions	1
Operating Precautions	2
Storing Precautions	4
Installation	5
Operation	6
Special Lubricating Oil	7
Periodical Inspection	9
Troubleshooting	10
Disassembly & Reassembly	11

Safety Precautions

Be sure to read before use.



Thank you for purchasing the Nidec Drive Technology product. To use this product properly and safely, please be sure to read this manual thoroughly before use.

Keep this instruction manual where all users can read and/or refer to it at any time.

Before use, please carefully read these safety precautions and follow them for proper use.

This instruction manual categorizes safety precautions as DANGER, WARNING, and CAUTION according to level of importance. Each precaution has an important explanation related to safety. Be sure to observe all precautions.



DANGER

Indicates a potentially hazardous situation that may result in fire, serious injuries, and/or death if you incorrectly handle this product by neglecting the following precautions.



WARNING

Indicates a potentially hazardous situation that may result in serious injury if you incorrectly handle this product.



CAUTION

Indicates a potentially hazardous situation that may result in minor or moderate injury and/or property damage if you incorrectly handle this product. However, more severe results may also occur depending on the situation if mishandled. Be sure to observe all precautions.

The type of precautions we would like you to observe is categorized using the following symbols, and explanations are added (some examples as given below).



A reminder to pay close attention.



A prohibited action you must not do.



A forced action you must always do.

- We are not responsible for damages resulting from negligence through failure to follow the instructions set out in this manual.
- We are not responsible for damages resulting from earthquake and/or fire unrelated to us, actions by third parties, or any other accidents, intentional or through customer negligence, as well as from accidents caused by misuse or improper use under abnormal conditions.
- For information regarding assurance provisions, please read the attached warranty certificate.

Precautions for installation

<p>Do not connect this product to a power source beyond the specified voltage range. If you connect the product to a power source beyond the voltage range indicated on the motor nameplate, the heated motor could result in motor burns and fire.</p>	<p>Be careful of electric shock during connection. Do not connect the product with wet (or sweaty) hands. Before wiring, be sure to turn the power OFF. Failure to follow this could result in electric shock.</p>
<p>Do not touch the keyway on the input and output shafts with bare hands. Be careful to touch the keyway. Failure to follow this could result in injury on your hands or fingers due to the sharp edges.</p>	<p>Do not install Ringcone in a place directly exposed to rain or water. Failure to follow this could result in electric shock, fire, and/or malfunction. When you use or install the product outdoors, select an outdoor model.</p>
<p>Install the product on a rigid surface that is not prone to vibration. If the installation surface is not rigid enough, the machine could fall over during operation or a device could be damaged due to excessive vibration.</p>	<p>Mount a safety cover on the rotational items. Failure to follow this could result in injury on your hands or fingers if you come into contact with the rotational items.</p>
<p>Do not install the product in an area with an ambient temperature of lower than 0°C and higher than 40°C.</p>	<p>If you use the product in a transportation device, or lifting device, apply protective device like brake for safety.</p>
<p>Disconnect the power supply for motor, when connecting.</p>	<p>To prepare pan or something for an oil leakage, if the leaking makes serious issues on application such as food, chemical machines, etc.</p>
<p>Heavy! Be careful when carrying. Failure to follow this could result in serious injury if you drop the product on your feet accidentally during carrying or installation.</p>	

Precautions for operation

<p>Do not use the product in an atmosphere with a risk of fire and/or explosion. If you use this product in an atmosphere with risk of fire and/or explosion, select the explosion-proof model.</p>	<p>Do not touch the unit because it may become hot during operation. Failure to follow this could result in burns.</p>
<p>Do not touch the rotating parts during operation. Do not touch the output shaft, input shaft, or fan.</p>	<p>Avoid operation overloaded. If you operate the unit with overload, the heated motor could result in motor burns and/or fire.</p>
<p>Before rotating the motor reversely, be sure to stop it completely.</p>	

Precautions for inspection and maintenance

<p>Turn the power OFF during inspection. Confirm the power source complete off before inspection & maintenance.</p>	<p>Do not touch the unit during operation and immediately after operation stops. The housing temperature will not decrease immediately after operation stops. Confirm that the temperature of the product has decreased before touching for inspection and/or disassembly.</p>
--	---

Operating Precautions

About this product

■ Input Speed

- Allowable input speed: RX-200B to 3700 ... 700rpm to 2000rpm based on the standard specifications.
RX-5500 / 7500 ... 900rpm to 1800rpm

When using the product with a lower input speed than the above, please contact us.

■ Output Speed

- When using product continuously, use it in the middle and high-speed areas, which secures high efficiency.
- If a special request was not given at the time of order, the rotation speed is set to 0 rpm when a light load is applied.
- If you continuously use this unit in the low-speed area of 100 rpm(*1) or less, it could be susceptible to load changes, and the rotation speed might become unstable.
- When continuously using the RX model with the output speed of 200 rpm (*1) or less, reduce load to 80% or less.

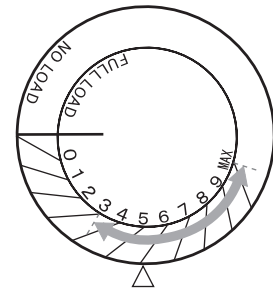

Middle- and high-speed areas...
Indicates the range between 3 and MAX on the dial.

■ Dial Plate & Load

- The output speed will not change as long as a load does not change. If a load changes greatly, however, the output speed might change even at the same dial plate position
- Note that the output speed might change if a load changes greatly.

*We recommend using the automatic control when high accuracy is desired.

(*1) Output speed without the reducer

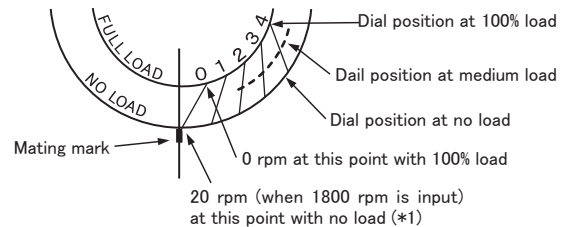

■ Lubricating oil

Lubricating oil plays an important role, which can be used not only for power transmission, but also for burn, wear, rust prevention, and for cooling. Since lubricating oil greatly influences the performance of the product and service life, be sure to use the special lubricating oil only.

- Be sure to use the specified lubricating oil.
- Do not mix any other lubrication.
- If you use this product in an area with an ambient temperature of 0°C or less, or 40°C or more, heat- or cold-resistant lubricating oil is required.
- Since, unless otherwise requested, the speed drive is filled with the proper amount of lubricating oil before shipping, additional lubrication is not required.
- Check the oil level every day.
- Keep the replacement interval, and replace accordingly.

*Refer to “[3](#) Special lubricating oil” described on page 7.

For purchase of the lubricating oil (special traction drive oil for the speed change section), contact us or any of the ENEOS Corporation offices.

Precautions during operation

- At initial operation, confirm the rotating direction of the output shaft, and gradually apply the load.
- The handle rotational direction and increasing or decreasing speed may depend on the handle mounting direction. For more information, please contact us.
- The surface temperature of the speed drive housing under normal operation can reach up to approximately 50°C higher than the ambient temperature.
- Switch between forward and reverse rotation after the motor (input) shaft stops completely.
- Never change the speed when operation stops.
- Be careful not to overload.

Inspection

◎ If abnormal high temperature, noise, vibration, and/or oil leakage occur, stop operation immediately and contact us.

■ Daily inspection

- Check to ensure that the load condition is appropriate.
- Check to ensure that the speed drive housing temperature is not extremely high during operation (A temperature of up to approximately 50°C higher than the ambient temperature will not cause any problems).
- Check to ensure that there is no abnormal rolling noise with the bearings and/or traction drive parts.
- Check to ensure that abnormal vibration is not being generated from the speed drive.

<Lubricating oil inspection>

- Check to ensure that the lubricating oil is supplied to the appropriate indication level (check when operation stops).
- Check to ensure that the lubricating oil is not dirty, and that the degree of transparency is high.
- Check to ensure that there is no oil leakage (for example, check oil seals on the input and output shaft parts, O-rings, oil gauge, and the area around the oil filling and drain ports).

■ Periodical inspection (every three months)

- Check to ensure that pulleys, sprockets, and speed drive mounting bolts are not loose.
- Check to ensure that there are no problems in the electrical system.
- Check to ensure that the load condition is appropriate.
- Replacement of lubricating oil
*Refer to “3-1 Special lubricating oil list” and “3-2 Replacement of lubricating oil” , and use the special lubricating oil.

Storing Precautions

If you do not plan to use the product immediately after purchase, store it under the following precautions.

To store temporarily

- (1) Store the product in a clean and dry place.
- (2) If you store the product outdoors or in a humid place, put it in a box, seal the box, and cover with plastic sheets.
- (3) When storing, attach a red rubber stopper into the air release plug, or set a plug stopper to prevent humidity from entering the product.

To store for a long period of time

- 1) When storing the product in outdoor areas subject to a lot of rain and/or humidity after installing on the site
 - (1) Cover the whole product with a water-proof sheet, and fix the sheet securely to prevent it from coming off due to strong wind, as well as to avoid entering rain and/or dust from clearance gap.
 - (2) If moisture is expected to evaporate from the ground, put the water-proof sheet underneath to prevent exposure to humidity from the evaporation, filling inside the sheet.
 - (3) When storing, attach a red rubber plug into the air release plug, or set a plug stopper to prevent humidity from entering the product.
 - (4) Set the cover on the motor terminal box, and seal the lead wire openings to avoid humidity from entering through the terminal box to the inside of the motor.
- 2) When storing the product indoors

When there is less humidity, cover the product with a plastic bag, etc., and follow the procedures described in (3) and (4) above.
- 3) When storing the product for a long period of time, over a year, special rust-proofing specifications are required in addition to the above procedures.
- 4) Rust-proofing intervals and procedures

Rust-proofing interval	Within one year (our shipping standard)		Over one year to less than three years (our recommendation)			
Instructions at ordering	No particular instructions are necessary		"Special rust-proofing specifications" need to be instructed			
Rust-proofing area	Rust-proofing procedures at factory shipping	Rust-proofing oil agent	Rust-proofing procedures at factory shipping	Rust-proofing oil agent	Procedures after shipping	
Exposed parts of the product, input/output shafts, and flange section	Input/output shafts After rinsing, wrap plastic tape around.	JIS K2246 NP-2	Input/output shafts After rinsing, apply the rust-proofing oil agent to them, and wrap plastic tape around.	Equivalent to JIS K2246 NP-19 Taiyu Sabiden SAP D-15K, or equivalent	Check the condition of the rust-proofing one year after shipping, and re-apply the rust-proofing oil, if necessary. After that, carry out the same procedure every year.	
	Flange section After rinsing, apply the rust-proofing oil agent to it, and pack the whole part with a plastic bag.	Idemitsu Daphne Evercoat PL, or equivalent	Flange section After rinsing, apply the rust-proofing oil agent to it, and pack the whole part with a plastic bag.			
Inside of the product	Grease	Special grease supplied at shipping	-	Special grease supplied at shipping	-	No special procedures are necessary
	Oil	Special oil supplied at shipping (The air breather has been sealed)	-	Add special oil thoroughly inside the housing. (The air breather has been sealed)	-	Take the same procedures as in the left, two years after shipping. When starting operation, replace with new oil, and fill to the specified level.

Note: Only when the export rust-proofing specifications or instructions are given, rust-proofing oil is applied to the input/output shafts even in less than one year.

Inspection during storage

Perform periodical inspection to check that the aforementioned storage procedures have been taken properly, and that the storing methods are correct.

Inspection before resuming operation

- (1) Return the product to normal conditions from those taken for storage (such as for the amount of special oil).
- (2) Since bearings may partially run out of grease resulting from the grease hardening during long-term storage, be sure to turn the motor shaft by hand from the fan side before operation, and check that there are no problems.
- (3) Since exposed parts of rubber and/or resin parts in the oil seal, O-ring, and oil gauge, etc., may become deteriorated due to environmental influences, such as temperature, humidity, and/or ultraviolet rays, check those parts before resuming operation. If any deterioration is found, replace with new ones.

1 Installation

1-1 Installation

- Avoid installing the product in a place directly exposed to rain or water.
 - Consult us in advance if you use the product outdoors, or in a place exposed to dust or water.
- Install the product in an area with an ambient temperature of between 0°C and 40°C.
 - If you plan to use the product beyond the above mentioned temperature range (at higher or lower temperature), be sure to consult us.
- Securely fix the product using bolts on a solid installation bench that is not prone to vibration.
 - Install the horizontal type horizontally, the vertical type (with downward output shaft) and inverted type (with upward output shaft) vertically. Failure to follow this could result in malfunction due to poor lubrication.
 - For inclined installation, consult us.
- Install the product in a way that provides easy access for inspection and maintenance.
 - To make it easy to add and drain lubricating oil, install the product at a level of approximately 10 cm from the floor by securing a top clearance of approximately 30 cm.
 - When installed the product into machines, place it so that the oil level can be checked externally, and lubricating oil can be easily replaced using pipes.

[Output shaft direction and installation direction]

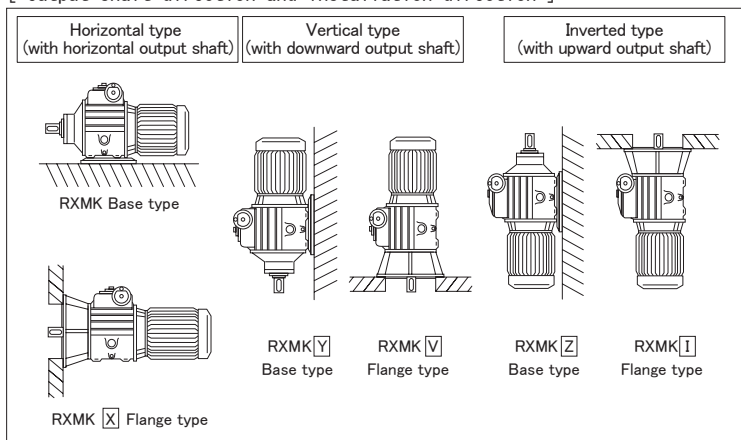

[Installation conditions]

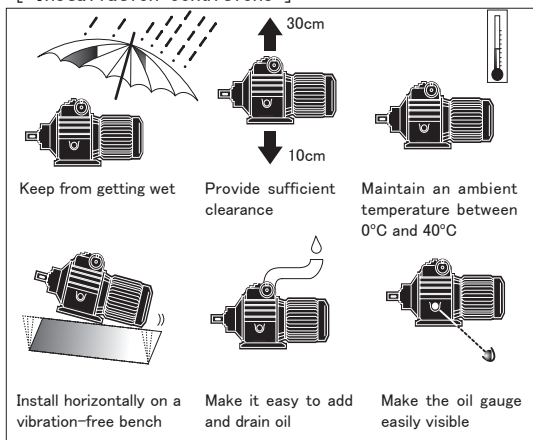

1-2 Connections

- Allow a sufficient margin when setting the rotating speed and torque.
 - When driving the mated machine at the maximum speed, connect the speed drive so that it also operates at the maximum rotation.
 - For machines of which torque increases at the lower speed (such as those with constant horsepower characteristics), set the maximum torque to be within the rated torque of the speed drive.
- When connecting the product, do not apply impact force and/or excessive thrust load on the output shaft (use tapping hole on the output shaft for 5500, 7500).

Ⓐ Since the output shaft diameter dimension tolerance of the speed drive has been set to h6 for 200B to 3700, and m6 for 5500, 7500, set the hole tolerance of the coupling, pulley, chain sprocket, and gear, which are to be mounted, to H7 for 200B to 3700, and F7 for 5500, 7500. Then, push the output shaft into the hole by tapping with a wooden or plastic hammer. Pushing the shaft by hitting it hard could result in damage to bearings and/or the inside of the speed drive.

- Chamfer the hole mouth by approximately 1 mm.
- Make clearance of 0.1 mm to 0.2 mm for the key head.
- Hold and secure the key head using a set bolt.

Note: Make the effective diameter of the coupling, pulley, chain sprocket, and gear, etc. at least five times the output (input) shaft diameter of the speed drive. Be careful not to allow impact, vibration, and/or excessive thrust load from the machine to apply to the shaft ends. (For information about allowable shaft weight, refer to the catalog).

- Ensure centering before connection.

- For connection with a coupling, properly align the speed drive shaft with the mated machine shaft.
- For connection with pulley, chain sprocket, and gear, etc., properly make the speed drive shaft parallel with the mated machine shaft, determine the correct center line, and fit precisely.

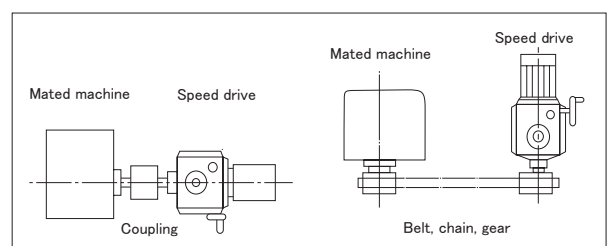
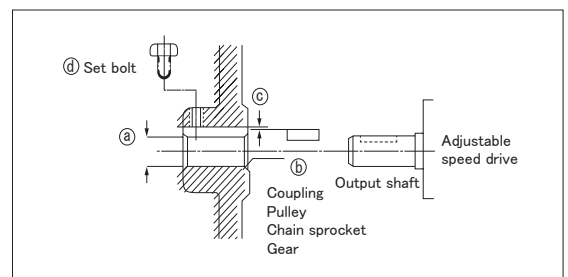

Note: The output shaft rotation direction for the speed drive equipped with a Coronet speed reducer (N11, 17, 29, 35, 47, 59, 71 types) is the same as that of the input shaft.

2 Operation

2-1 Precautions before starting operation

1. Since, unless otherwise requested, the speed drive is filled with the proper amount of lubricating oil before shipping, additional lubrication is not required *

(Before use, check that lubricating oil has been supplied at the specified level of the oil gauge just in case).

* Note that models with the rod-shaped oil gauge have not been filled with lubricating oil. (refer to page 8.)

■ Before use, be sure to remove the (red) pressure-release rubber plug attached to the breather cap at the oil filling port. Also, for models equipped with the reducer (G, N, N types), be sure to remove the (red) pressure-release rubber plug attached to the oil port cap of the reducer.

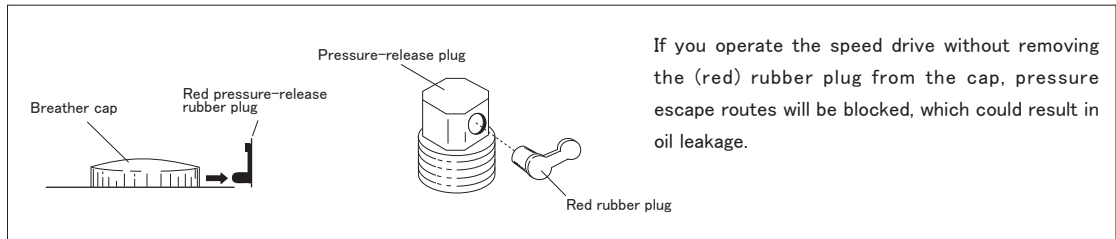

2. Check that electrical wiring has been performed properly.
3. Check that connection to the mated machine has been performed properly (fitting conditions, centering, etc.).
4. At initial operation, confirm the rotating direction of the output shaft, and gradually apply the load.

2-2 Precautions during operation

1. Never turn the speed change handle when operation stops (when the motor is not running).
2. Be careful not to overload.
3. The surface temperature of the speed drive housing under normal operation can reach up to approximately 50°C higher than the ambient temperature.
4. Since continuously operating the unit (without the reducer) with an output shaft rotation speed of 200 rpm or less under the rated load could result in temperature increase, we recommend operating by reducing the load to 70% to 80% or less, or selecting time rated operation (for 30 minutes).
If ambient temperature resulting from heat generation in the speed drive adversely affects the operating environment, reduce load to suppress heat generation, or contact us.
5. If the following events occur, stop operation immediately, and inspect the unit. Take any necessary procedures.

Symptoms	Possible causes
<ul style="list-style-type: none"> • The temperature suddenly increases. • An abnormal, loud noise is suddenly generated. • The rotation speed suddenly becomes unstable. • Other abnormal events are found. 	<ul style="list-style-type: none"> • The unit has been overloaded • Lubricating oil has been excessively or insufficiently used, or has deteriorated. Or, a different type of lubricating oil has been used. • Bearings and/or drive surfaces have been damaged • Improper connecting conditions with the mated machine, etc.

* For more details on the above symptoms and possible causes of problems, refer to "[5] Troubleshooting" on page 10.

6. Switch between forward and reverse rotation after checking that the motor (input) shaft has stopped operation completely.
Instantaneous switching between forward and reverse rotation could result in malfunction.

2-3 Dial graduation and load

For RX, the rotation will not change as long as the load does not change.

If a load changes greatly, however, the rotation speed will change even at the same graduation point.

1. Read the graduation on the dial depending on the load.
2. Note that the rotation speed will change if a load changes greatly.
(We recommend using the automatic control when high accuracy is desired).

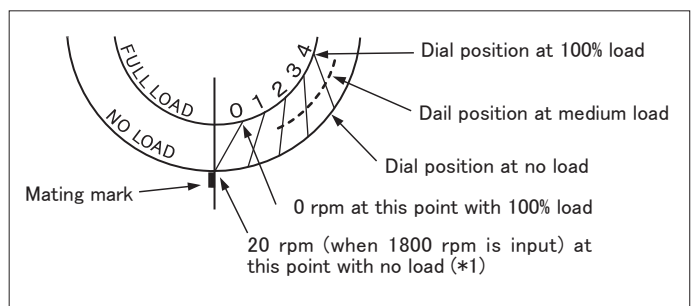

(*1) Rotation speed for the type without the reducer

3 Installation

3-1 Special Lubricating Oil

Lubricating oil plays an important role in power transmission, and also has various effects on burn, wear, and/or rust prevention, and/or cooling. Since lubricating oil greatly influences the performance of the product and product life, be sure to use the special traction drive oil for the speed change section. The type of lubricating oil differs between the speed change and speed reduction sections. In the event that different types of oil are used, sufficient performance may not be attained, or extension of the product life may be greatly influenced.

■ The type of lubricating oil differs between the speed change and speed reduction sections. In the event that different types of oil are used, sufficient performance may not be attained, or extension of the product life may be greatly influenced.

Speed drive				Planetary/Pinion reducer		Inscribed planetary reducer			Worm reducer		
Speed drive model	RX-60 to 3700 NRX-60 to 7500 ARX-60 to 750 SC-200E to 22000C O-200E to 1500E	RX-5500 7500 NRX-11K 15K	RX-11K to 15K NRX-18K to 30K	RX-60 / 90 NRX-60 / 90 ARX-60 / 90	RX-200B NRX-200B / 400B	RX-400 to 7500 NRX-750 to 18K ARX-400 to 750 SC-200E to 22000C O-200E to 1500E	RX-90 NRX-90 ARX-90	RX-200B to 15K NRX-200B to 30K ARX-400 to 750 SC-200E to 3700E O-200E to 1500E	RX-90 to 3700 NRX-90 to 5500 ARX-90 to 750 SC-200E to 3700E O-200E to 1500E		
Lubrication system	Speed change section		Gear section	G3M / G5M		G3 / G5 / G6	G11 to G71	NG/11 to 71 C11 to 87			
	Oil lubrication		Forced oil lubrication	Oil lubrication		Oil		Oil			
Type	Special traction drive oil for the speed change section		JIS K 2219 Industrial Gear Oil Class 2 ISO VG220	NLGI No.1 Grease		JIS K 2219 Industrial Gear Oil Class 2 ISO VG220	JIS K 2213 Turbine Oil Class 2 ISO VG46	NLGI No.2 Grease	JIS K 2219 Industrial Gear Oil Class 2 ISO VG100		
Brand	Idemitsu	RINGCONE Traction Drive Oil TD Oil 10	RINGCONE Traction Drive Oil TD Oil 22	Daphne Super Gear Oil 220	Daphne Coronex EP No.1	Daphne Polyplex No.0	Daphne Super Gear Oil 220	Daphne Mechanic Oil 46	Daphne Super Gear Oil 100		
	ENEOS			Bonnoc TS220	Epnoc Grease API1	Pyronoc Grease No.0	Bonnoc TS220	FBK Oil R046	Bonnoc TS100	Bonnoc TS320	
	Mobil			Mobilgear 600XP 220	Mobilux EP No.1	Stamina RL No.0	Omala S2G 220	Tellus S2M 46	Omala S2G 100	Mobilgear 600XP 100	Mobilgear 600XP 320
	Showa Shell			Omala S2G 220	Alvania EP No.1	–	–	–	–	–	–
	Cosmo			Cosmo Gear SE 220	Dynamax EP No.1	–	Cosmo Gear SE 220	Cosmo Allplus 46	–	Cosmo Gear SE 100	Cosmo Gear SE 320
	–			–	Unilube DL No.1	–	–	–	–	–	–
	–			–	Excellite EP No.0	–	–	–	–	–	–
Replacement interval	Every 20,000 hours, or every 4 – 5 years	Every 5,000 hours, or every year	Every 20,000 hours, or every 4 – 5 years	Every 5,000 hours, or every year	Every 20,000 hours, or every 4 – 5 years	Every 5,000 hours, or every year	Every 20,000 hours, or every 4 – 5 years	Every 5,000 hours, or every year			

Note 1. For lubricating oil supplied at shipping, contact us accordingly.

2. The oil replacement interval differs depending on conditions of use. In particular atmospheres subject to high humidity and/or active gas, shorten the replacement interval described in the above table.

- When using the product at especially low temperatures (approximately -30°C to 0°C) or high temperatures (approximately 40°C or more), heat or cold-resistant lubricating oil and applicable internal parts are required. For details, consult us in advance.
- For purchase of special traction drive oil, contact us or any of the ENEOS Corporation offices.

3-2 Replacement of lubricating oil

■ Speed change section

For special traction drive oil, the oil lifespan is extremely long, and the replacement interval is very long.

* For the replacement interval, refer to the above table.

■ Speed reduction section

Replace lubricating oil described in the above table at the specified replacement interval.

3-3 Oil filling and draining

■ Never mix different types of oil. Failure to follow this could result in adverse effect due to the change in oil quality.

■ Oil leakage could result in accidents. Wipe away oil spills at the time of filling or draining.

[For the speed change section]

■ Add oil up to the specified level of the oil gauge when the speed drive stops.

Note: Continuing operation with insufficient oil could result in damage to internal parts.

Check the oil level every day.

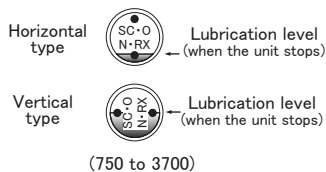
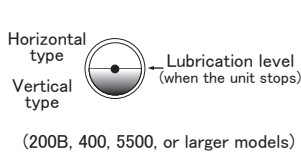

Note: For the vertical type, be sure to set the unit vertically before adding oil. If oil is added with the unit placed horizontally, the amount of oil will differ, and proper lubrication management cannot be performed. If oil has been added excessively, remove the drain plug, and drain out surplus oil to adjust the amount.

[For the speed reduction section]

■ The plug position in the center of the speed reduction section indicates the proper oil level. Remove the upper lubrication plug and level plug, and fill with oil until oil flows out of the level plug.

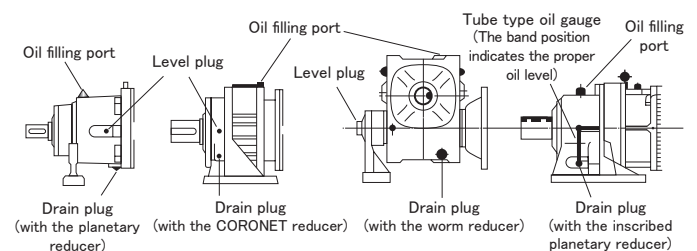

■ For the grease lubricated system <Frame A/B/C of N(G)11 to 71>, additional refill is not required in the middle of the replacement interval. When replacing oil, disassemble the unit for overhaul before lubrication.

Note: Before adding oil in the vertical type of model 200B to 750, be sure to remove the attached pressure relief plug for lubrication, which can be used to release the internal air pressure.

3-4 Proper amount of oil, and oil filling/draining plug positions

RX □ (L)

Model	Horizontal type	Vertical type
	Speed change section	Speed change section
200B	0.2	0.4
400	0.5	1.0
750	0.8	1.9
1500	1.8	2.7
2200	2.5	4.8
3700	2.8	5.4
5500	5.0	15
7500	5.0	15

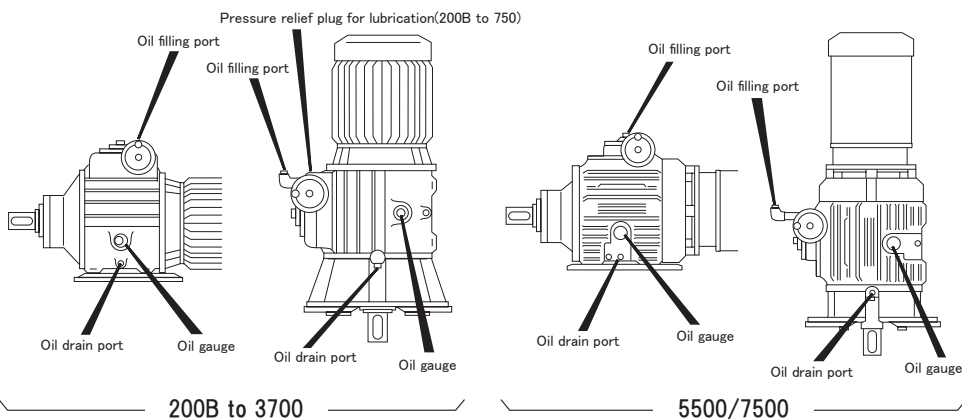

RX □ - □ -G □ Planetary/Pinion reducer (L)

Model	Reduction ratio	Horizontal type		Vertical type	
		Speed change section	Speed reduction section	Speed change section	Speed reduction section
200B	G3M/G5M	0.2	Grease	0.4	Grease
400	G3/6	0.5	0.4	1.0	0.4
750	G3/6	0.8	0.5	1.9	0.5/0.8
1500	G3/6	1.8	1.0	2.7	0.8/1.3
2200	G3/6	2.5	1.5	4.8	1.3/2.3
3700	G3/6	2.8	1.8	6.5	2.0/3.5
5500	G3/5	5.0	9.0	15	18.2
7500	G3/5	5.0	9.0	15	18.2

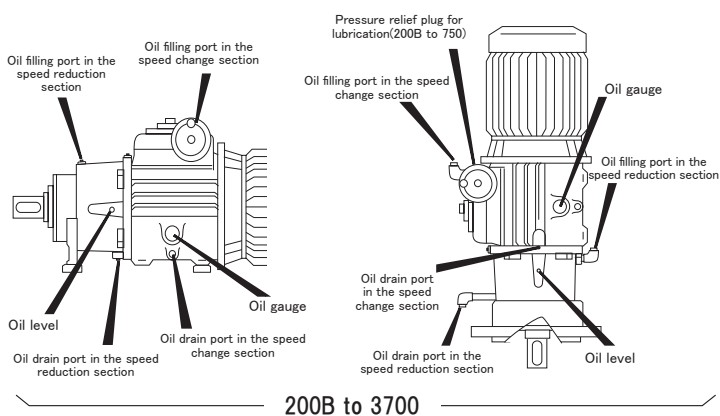

The vertical type RXV-G3 is equipped with the rod-shaped oil gauge in the standard specifications.

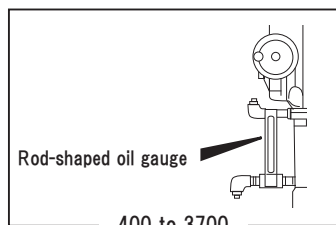

*Add oil up to the red line.

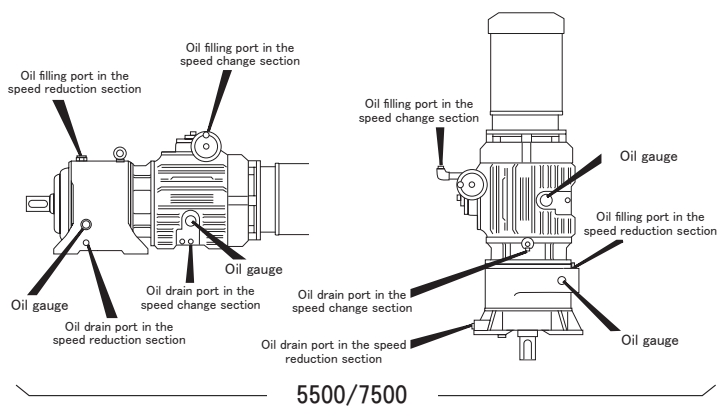

RX □ - □ -W □ Worm reducer (L)

Model	Speed change section	Speed reduction section			
		H □ U	V □ D	V □ U	
200B	W10	0.2	0.25	0.4	0.4
	W20/30	0.2	0.5	0.6	0.6
400	W10	0.5	0.5	0.6	0.6
	W20/30	0.5	0.7	0.85	0.85
750	W10	0.8	0.7	0.85	0.85
	W20/30	0.8	1.3	1.5	1.5
1500	W10	1.8	1.3	1.5	1.5
	W20/30	1.8	2.1	2.7	2.7
2200	W10	2.5	2.1	2.7	2.7
	W20/30	2.5	3.3	4.1	4.1
3700	W10	2.8	3.3	4.1	4.1
	W20/30	2.8	5.5	7.5	7.5

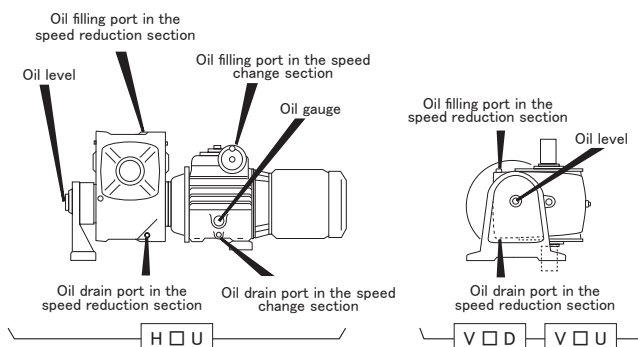

3-4 Proper amount of oil, and oil filling/drain plug positions

RX □ - □ - $\frac{N}{C}$ □ Inscribed planetary reducer(L)

Model	Reduction ratio	Frame size	Horizontal type		Vertical type	
			Speed change section	Speed reduction section	Speed change section	Speed reduction section
200B	N11 to 71	B	0.2	Grease	0.4	Grease
400	N11	B	0.5	Grease	1.0	Grease
	N17 to 71	C	0.5	Grease	1.0	Grease
750	N11 to 29	C	0.8	Grease	1.9	Grease
	N35 to 71	D	0.8	0.9	1.9	1.5
1500	N11 to 29	D	1.8	0.9	2.7	1.5
	N35 to 71	E	1.8	1.8	2.7	2.4
2200	N11	D	2.5	0.9	4.8	1.5
	N17 to 71	E	2.5	1.8	4.8	2.4
3700	N11 to 35	E	2.8	1.8	5.4	2.4
	N47 to 71	F	2.8	3.2	5.4	4.3
5500	C11 to 43	H	5.0	4.6	15	7
	C43/87	L	5.0	15	15	18
7500	C11 to 43	H	5.0	4.6	15	7
	C43/87	L	5.0	15	15	18

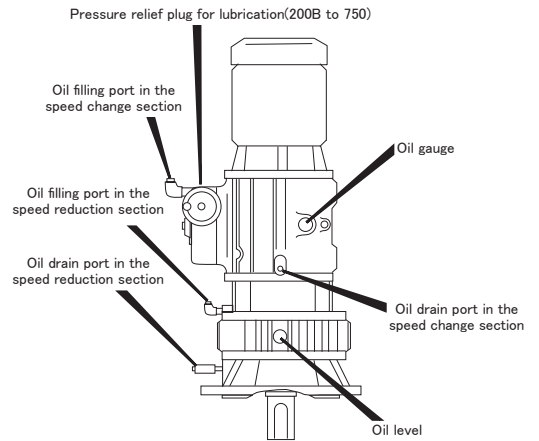
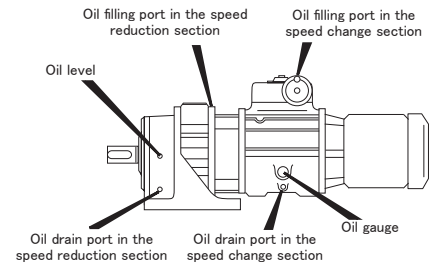

200B to 3700

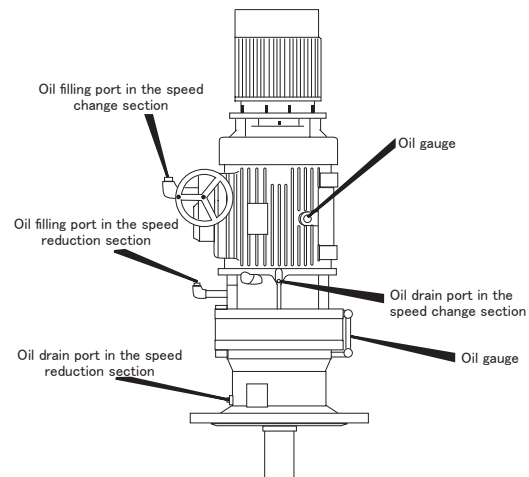
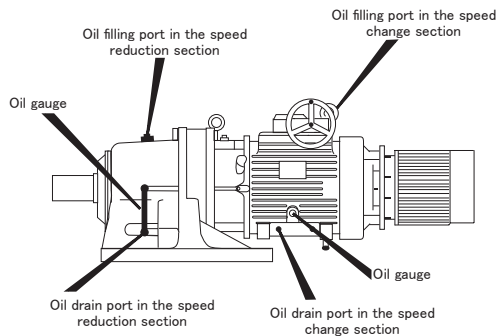

5500/7500

4 Periodical Inspection

4-1 Daily inspection

- Check to ensure that the speed drive housing temperature is not extremely high during operation.
 - * A temperature of up to approximately 50°C higher than the ambient temperature will not cause any problems.
- Check to ensure that there are no abnormal rolling sounds with the bearings and/or friction transmission parts.
- Check to ensure that abnormal vibration is not being generated from the speed drive.
 - * If any of these abnormal events occur, stop operation immediately, disassemble and inspect the unit, or contact us.
- Confirm that oil has been supplied at the specified level of the oil gauge (Check when the unit stops).
- Check to ensure that the oil has not been contaminated. Check to ensure that oil gauge is transparent enough.
- Check to ensure that there is no oil leakage anywhere (for example, in oil seals on the input and output shaft parts, O-rings, oil gauge, and/or the area around the oil filling and drain ports, etc.).
 - * If any oil leakage occurs, replace the necessary parts, or contact us.

4-2 Periodical inspection (approximately at least every three months)

- Check to ensure that there is no excessive overload.
- Check to ensure that pulleys, sprockets, and speed drive mounting bolts are not loose.
- Check to ensure that there are no problems in the electrical system.
- Inspect and maintain major parts.
 - * If abnormal sounds occur inside of the speed drive, stop operation immediately, disassemble and inspect the unit, or contact us.
- Check to ensure that the specified time of replacement for lubricating oil has not passed.
 - * Check to ensure that oil level has not decreased, and that it's not dark in color. Check the specified replacement interval.

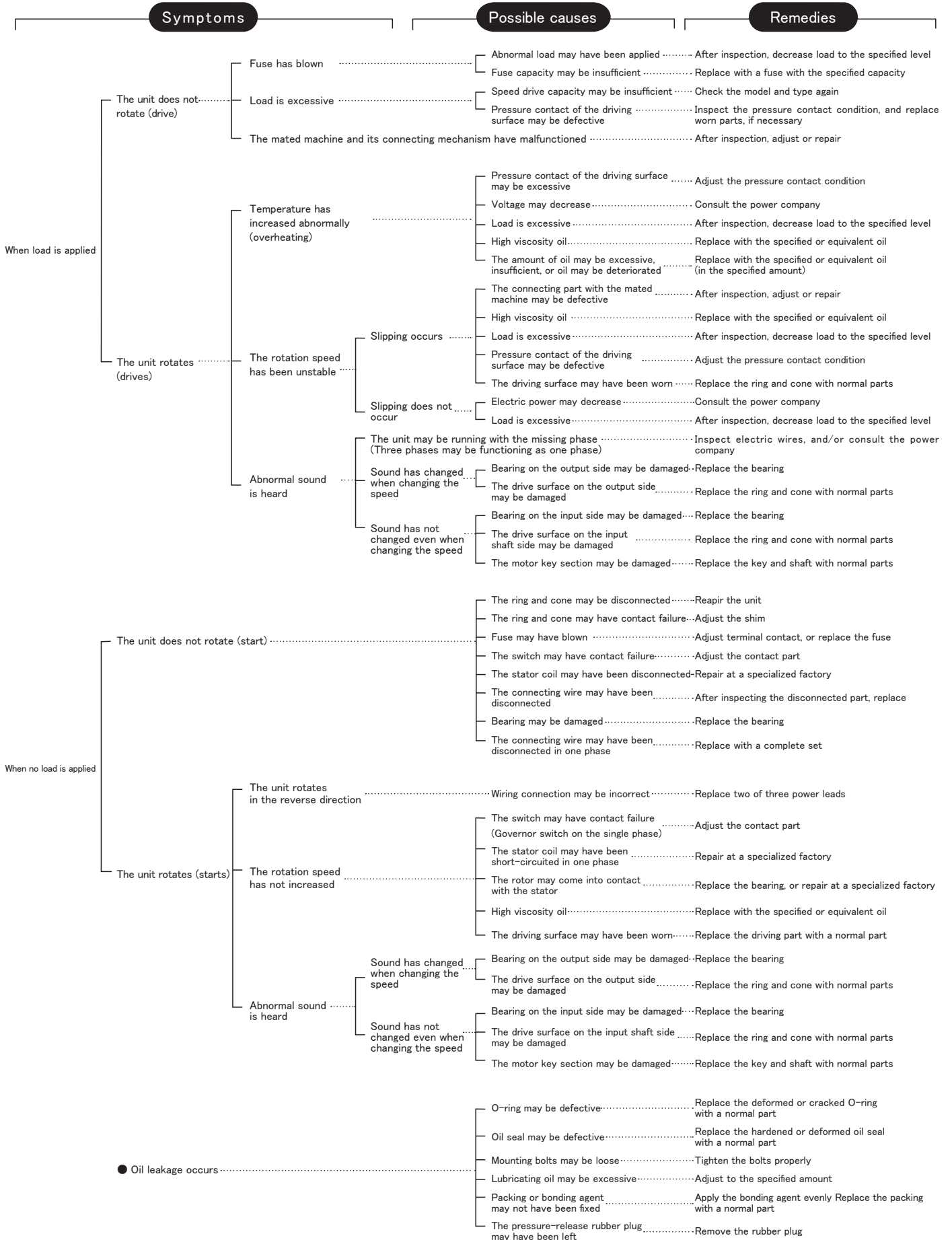

6 Disassembly & Reassembly

If problems or malfunction have occurred in the unit, and disassembly inspection is required, refer to the disassembly and reassembly figures on the following pages, and perform accordingly (refer to "[5] Troubleshooting" on page 10).

Note: Since models larger than the medium-scale type (1.5 kW type), and those equipped with the reducer have heavy parts, hoist or crane equipment may be required at the time of disassembly and reassembly.

Note: When disassembly and reassembly are performed by our workers, please have your company remove and mount the speed drive.

6-1 Disassembly procedure

- (1) Remove the plug from the oil drain port, and drain oil completely.
- (2) Remove the top cover.
- (3) Remove the output shaft assembly from the main unit.
- (4) Remove the cam assembly from the output shaft assembly.
- (5) Remove the cone assembly.
- (6) Remove the ring assembly.
- (7) Remove the input disc from the motor shaft.

• Inspection & Washing

- After disassembly, inspect each part, and wash all parts with washing oil.
- Replace defective parts with normal ones.

Keep all disassembled parts away from dust until reassembly.

6-2 Reassembly procedure

- Perform reassembly in the reverse order of disassembly.
- Put packing in joint parts between the M flange/output shaft holder/motor and the main unit housing/covers. In such cases, replace deformed or cracked packing with normal one.
- * When reassembly is complete, adjust pressure contact force inside according to "6-3 Shim (pressure contact force) adjustment".

6-3 Shim (pressure contact force) adjustment

- Since shim (pressure contact force) has been sufficiently adjusted at shipping, readjustment is not necessary before use.

When disassembly and reassembly have been performed due to unavoidable circumstances, readjust shim according to the following procedure.

RX *For models with the reducer, refer to the respective page.

● Adjustment procedure

When reassembly is complete after disassembly, in order for the "automatic pressure adjustment mechanism" to function effectively, adjust pressure contact force using the shim inside the bearing cover.

• When reassembling the speed change section, move the ring to the low speed end (output shaft) in advance.

● Procedure

- (1) Tighten the bearing cover completely.
- (2) Mount a pulley on the output shaft, and manually turn the pulley from side to side to seat internal parts.

RX <input type="checkbox"/> -200B/400 to 1500
Adjust by output shaft backlash

- (3) When turning the pulley from side to side, check that output shaft backlash is within the range of values in the table below.
If backlash is too large or small, remove the bearing cover, and adjust to the normal value by increasing or decreasing the shim (0.1 mm to 0.2 mm thick).

Model	Output backlash
200B/400/750	1° to 3°
1500	After adjusting to 1° to 3°, add a shim 0.2 mm thick.

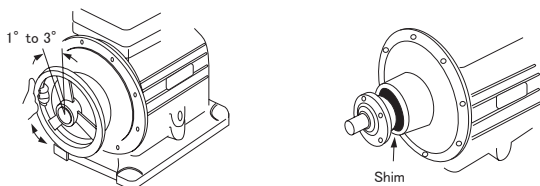

- (4) When shim (pressure contact force) adjustment is complete, mount the top cover, and set the dial.
Under no load, align the mating mark with 0 (zero) for NO LOAD on the dial, and tighten using the bolt.

RX <input type="checkbox"/> -2200 to 7500
Adjust by clearance between the cam disc and input cam

- (3) Remove the top cover.
- (4) Look into the inside of the main unit, and check that clearance between the cam disc and input cam is within the range of values in the table below.
If clearance is too large or small, remove the bearing cover, and adjust to the normal value by increasing or decreasing the shim (0.1 mm to 0.2 mm thick).

Model	Clearance of the cam disc
2200 to 7500	Adjust clearance to 0 to 0.1 mm, and add a shim 0.1 mm to 0.15 mm thick (0.05 mm to 0.1 mm thick when applying pressure).

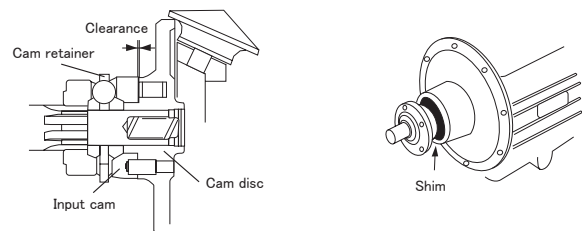

- (5) When shim (pressure contact force) adjustment is complete, mount the top cover, and set the dial.
Under no load, align the mating mark with 0 (zero) for NO LOAD on the dial, and tighten using the bolt.

RX□ - □ -G□ with planetary reducer

RX□ - □ -W□ with worm reducer

● When reassembly of the speed change and reduction sections is complete after disassembly, adjust pressure contact force according to the following procedure.

● When reassembling the speed change section, move the ring to the low speed end (output shaft) in advance.

● Procedure

(1) Remove the top cover in the speed change section, look into the inside, and adjust pressure contact force according to the following procedure.

(2) Only for W type (with worm reducer), loosen the hexagon socket set screw. *Refer to the disassembly and reassembly diagram for the worm reducer section on page 18

RX □ -200B / 400 to 1500-G □
RX □ -200B / 400 to 1500-W □
Adjust by cam retainer backlash

(3) Hold the cam retainer with pliers, etc., and check that the total backlash is within the range of values in the table below. If backlash is too large or small, remove the bearing cover (HS blind cover for W type), and adjust to the normal value by increasing or decreasing the shim (0.1 mm to 0.2 mm thick).

Model	Cam retainer backlash
200B/400/750	1° to 3°
1500	After adjusting to 1° to 3°, add a shim 0.2 mm thick.

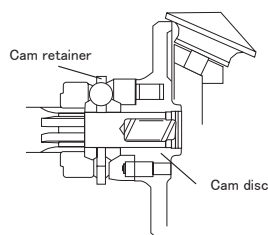
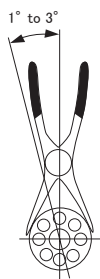

RX □ -2200 or larger -G □
RX □ -2200 or larger -W □
RX □ -5500/7500-C □ H/L
Adjust by clearance between the cam disc and input cam

(3) Look into the inside of the speed drive, and check that clearance between the cam disc and input cam is within the range of values in the table below. If clearance is too large or small, remove the bearing cover (HS blind cover for W type), and adjust to the normal value by increasing or decreasing the shim (0.1 mm to 0.2 mm thick).

Model	Clearance of the cam disc
2200 to 7500	Adjust clearance to 0 to 0.1 mm, and add a shim 0.1 mm to 0.15 mm thick (0.05 mm to 0.1 mm thick when applying pressure).

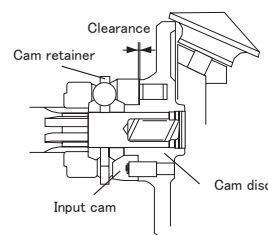

(4) Only for W type (with worm reducer), tighten the hexagon socket set screw after shim (pressure contact force) adjustment.

(5) Set the dial.

* Refer to the procedure for the standard RX □ on page 11.

- When reassembly of the speed change and reduction sections is complete after disassembly, adjust pressure contact force according to the following procedure.
- When reassembling the speed change section, move the ring to the low speed end (output shaft) in advance.
- Procedure

(1) Put a rod (T-wrench) etc. into the ER flange adjustment hole, and align the ER flange and adjuster surfaces on the same level by turning the adjuster. After that, assemble the main units of the speed reduction and change sections.

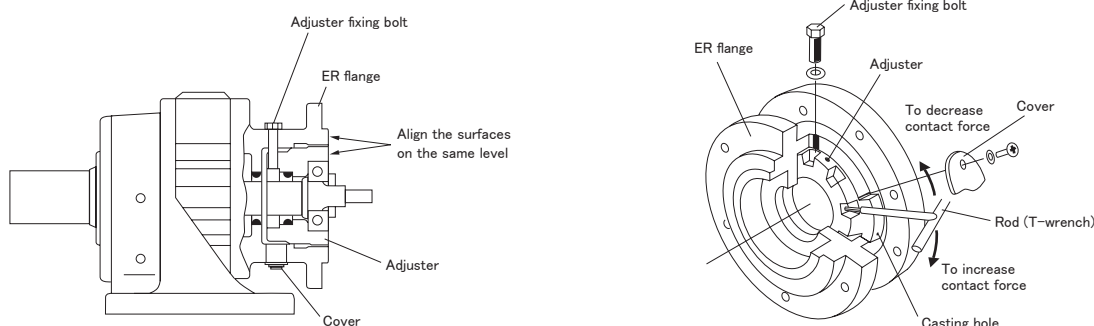

(2) Remove the top cover in the speed change section, look into the inside, and adjust pressure contact force by turning the adjuster with a rod (T-wrench) etc. according to the following procedure.

(3) Check pressure contact force adjustment according to the tables below.

(Turning the adjuster clockwise increases contact force, and turning counterclockwise decreases contact force when viewed from the output shaft)

RX □ -200B / 400 to 1500-N □
Adjust by cam retainer backlash

(4) Hold the cam retainer with pliers, etc., and check that the total backlash is within the range of values in the table below. If backlash is too large or small, turn the ER flange adjuster, and make adjustment.

Model	Cam retainer backlash
200B/400/750	1° to 3°
1500	After adjusting to 1° to 3°, turn the adjuster by one pitch to increase contact force

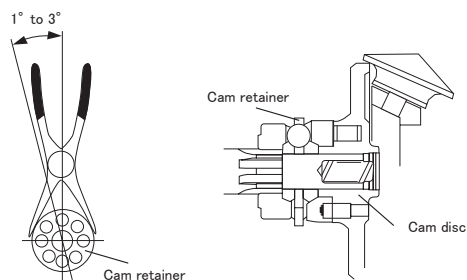

RX □ -2200 / 3700-N □
Adjust by clearance between the cam disc and input cam

(4) Look into the inside of the speed drive, and check that clearance between the cam disc and input cam is within the range of values in the table below. If clearance is too large or small, turn the ER flange adjuster, and make adjustment.

Model	Clearance of the cam disc
2200/3700	After adjusting clearance to 0 to 0.1 mm, turn the adjuster by one pitch to increase contact force

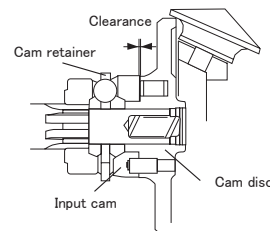

(5) When shim (pressure contact force) adjustment is complete, secure the adjuster using the fixing bolt, and set the blind bolt on the other side.

Note: The fixing bolt is used to keep the adjuster from turning. Keep the tip of the bolt from coming into contact with the bottom of the adjuster.

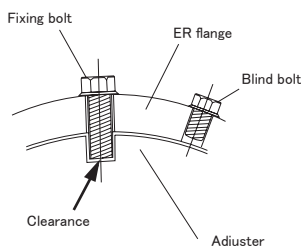

(6) Set the dial.

*Refer to the procedure for the standard RX □ on page 11.

Disassembly and reassembly diagram for speed change section 1 RXM (K) – 200B to 3700

* For the speed reduction section, refer to the disassembly and reassembly diagram for the respective speed reduction section on pages 17 to 20.

Bearing name number list

Bearing position	Output shaft A	Output shaft B	Output shaft C	Input disc D	Input disc G	Motor shaft E	Motor shaft F
200B	6203ZZ	6203	-	51204	-	-	-
400	6204ZZ	TMB204	-	51204	-	-	-
750	6206ZZ	TMB206	-	51305	-	-	-
1500	6207ZZ	6207	51207	51406	6008	-	-
2200	6208ZZ	6307	51307	51407	6010	-	-
3700	6210ZZ	6308	51308	51410	6011	6210LLU	6210LLU

A, B, E, F, G: Ball bearing (ZZ: metal seal type, LLU: contact rubber seal type) C, D: Thrust bearing

Vertical type of RXM(K)-200B

*The bearing type on the output shaft A is LLU.

When the sensor gear is attached, the bearing type on the output shaft B is also LLU.

Inverted type of RXM(K)-400 or larger

*The bearing type on the output shaft A and B is LLU.

Oil seal name number list

Seal position	Output shaft R	Input shaft S
200B	D17328	-
400	D20358	-
750	D30458	-
1500	D35508	-
2200	D40588	-
3700	D507212	S507212

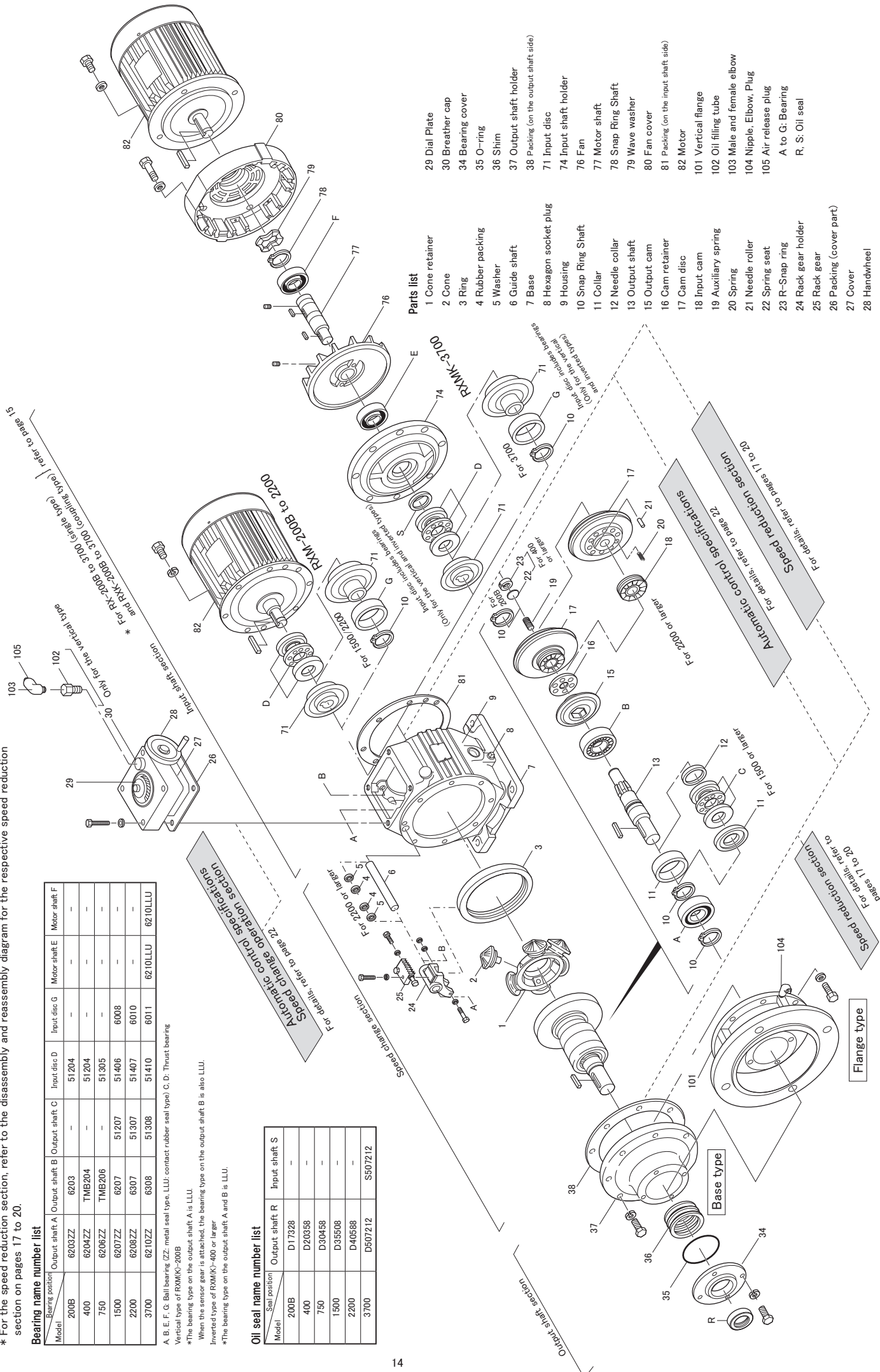

- Parts list**
- 1 Cone retainer
 - 2 Cone
 - 3 Ring
 - 4 Rubber packing
 - 5 Washer
 - 6 Guide shaft
 - 7 Base
 - 8 Hexagon socket plug
 - 9 Housing
 - 10 Snap Ring Shaft
 - 11 Collar
 - 12 Needle collar
 - 13 Output shaft
 - 15 Output cam
 - 16 Cam retainer
 - 17 Cam disc
 - 18 Input cam
 - 19 Auxiliary spring
 - 20 Spring
 - 21 Needle roller
 - 22 Spring seat
 - 23 R-Snap ring
 - 24 Rack gear holder
 - 25 Rack gear
 - 26 Packing (cover part)
 - 27 Cover
 - 28 Handwheel
 - 29 Dial Plate
 - 30 Breather cap
 - 34 Bearing cover
 - 35 O-ring
 - 36 Shim
 - 37 Output shaft holder
 - 38 Packing (on the output shaft side)
 - 71 Input disc
 - 74 Input shaft holder
 - 76 Fan
 - 77 Motor shaft
 - 78 Snap Ring Shaft
 - 79 Wave washer
 - 80 Fan cover
 - 81 Packing (on the input shaft side)
 - 82 Motor
 - 101 Vertical flange
 - 102 Oil filling tube
 - 103 Male and female elbow
 - 104 Nipple, Elbow, Plug
 - 105 Air release plug
 - A to G: Bearing
 - R, S: Oil seal

Disassembly and reassembly diagram for speed change section 3 RX (M) K-5500, 7500

*For details on the speed reduction section, please refer to the disassembly and reassembly diagram for the respective speed reduction section on pages 18 and 21.

Bearing name number list

Bearing position	Output shaft A	Output shaft B	Output shaft C	Input disc D	Motor shaft E	Motor shaft F	Input shaft G	Input disc H
Model	5500 / 7500	6312ZZ	81212	6312	89315	6213LLU	6311LLU	6013

A, C, E, F, G, H : Ball bearing (ZZ: metal seal type, LLU: contact rubber seal type)

B, D : Thrust bearing

For the inverted type, the bearing type on the output shaft A and C is LLU.

Oil seal name number list

Seal position	Output shaft R	Motor (Input) shaft S
Model	5500 / 7500	D608212
		S659013

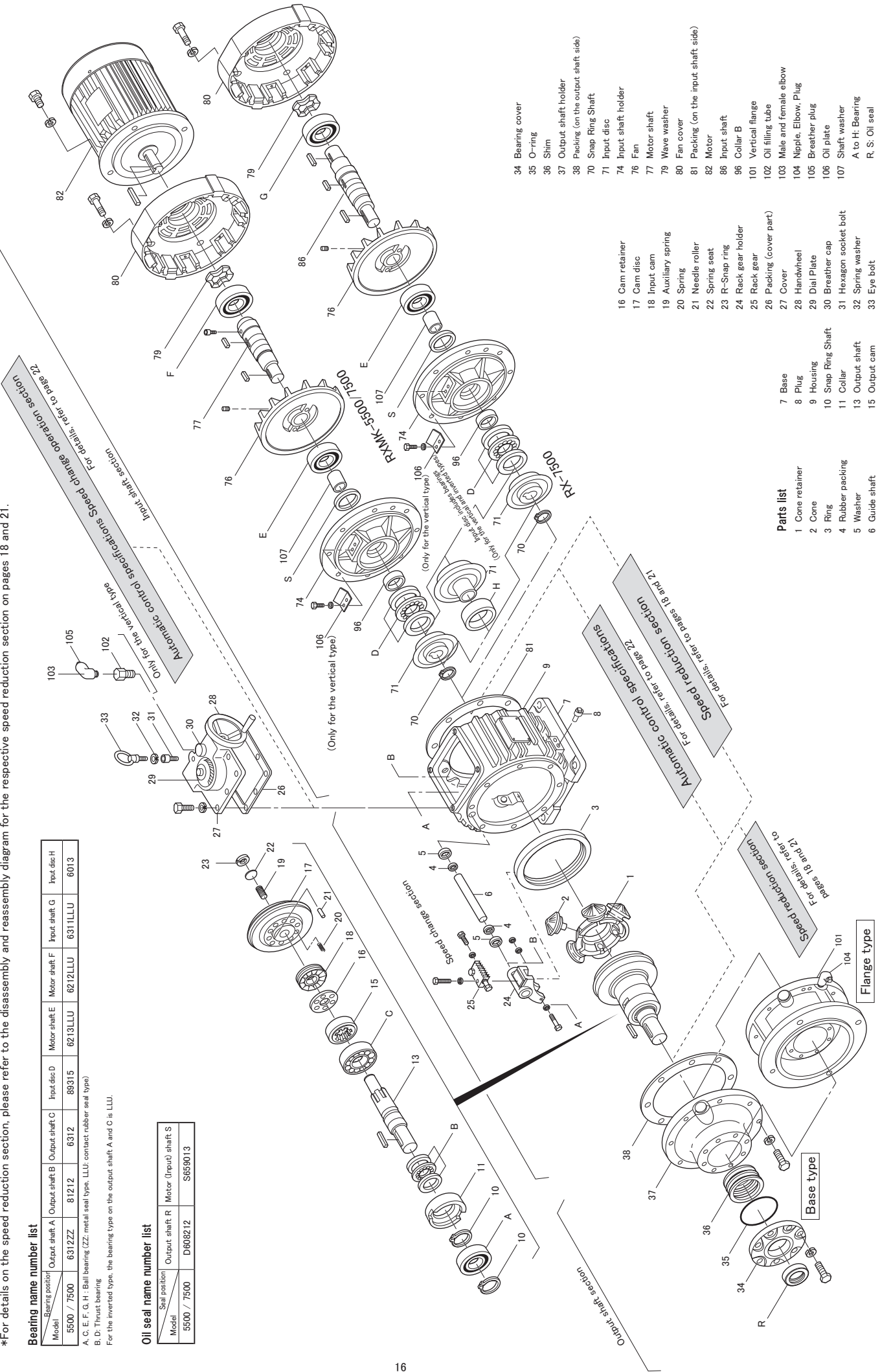

- 34 Bearing cover
- 35 O-ring
- 36 Shim
- 37 Output shaft holder
- 38 Packing (on the output shaft side)
- 70 Snap Ring Shaft
- 71 Input disc
- 74 Input shaft holder
- 76 Fan
- 77 Motor shaft
- 79 Wave washer
- 80 Fan cover
- 81 Packing (on the input shaft side)
- 82 Motor
- 86 Input shaft
- 96 Collar B
- 101 Vertical flange
- 102 Oil filling tube
- 103 Male and female elbow
- 104 Nipple, Elbow, Plug
- 105 Breather plug
- 106 Oil plate
- 107 Shaft washer
- A to H: Bearing
- R, S: Oil seal

- 16 Cam retainer
- 17 Cam disc
- 18 Input cam
- 19 Auxiliary spring
- 20 Spring
- 21 Needle roller
- 22 Spring seat
- 23 R-Snap ring
- 24 Rack gear holder
- 25 Rack gear
- 26 Packing (cover part)
- 27 Cover
- 28 Handwheel
- 29 Dial Plate
- 30 Breather cap
- 31 Hexagon socket bolt
- 32 Spring washer
- 33 Eye bolt

- 7 Base
- 8 Plug
- 9 Housing
- 10 Snap Ring Shaft
- 11 Collar
- 13 Output shaft
- 15 Output cam

- 1 Cone retainer
- 2 Cone
- 3 Ring
- 4 Rubber packing
- 5 Washer
- 6 Guide shaft

Parts list

- 1 Cone retainer
- 2 Cone
- 3 Ring
- 4 Rubber packing
- 5 Washer
- 6 Guide shaft

Disassembly and reassembly diagram for planetary reducer section 1 RXM (K) -200B-G3M, G5M / RXM (K) -400 to 3700-G3, G6

*For the speed change section, refer to page 14.

200B | G3M / G5M

Bearing name number list

Model	Bearing position	Output shaft 2A	Input shaft 2C	Input shaft 2D
200B		6205ZZ	6204ZZ	6303

2A, 2B, 2C, 2D: Ball bearing (ZZ: metal seal type)
The bearing type on the input shaft 2C/2D for the inverted type is LLU when the sensor gear is attached.

Oil seal name number list

Model	Seal position	Output shaft 2R	Input shaft 2S
200B		D25408	S20358

400 to 3700 | G3 / G6

Bearing name number list

Model	Bearing position	Output shaft 2A	Output shaft 2B	Output shaft 2C	G3 Planetary gear 2D	G6 Planetary gear 2E	Input shaft 2G
400		6206LLU	6007	4T-30203	HK 1212(2)	IR 8x12 x12.5(2)	6203ZZ
750		6207LLU	6009	4T-30204	HK 1516(2)	IR 12 x15 x15.5(2)	6205ZZ
1500		4T-30208	6010	4T-30205	6001(4)	-	6206ZZ
2200		4T-30210	6012	4T-30206	6002(4)	-	6207ZZ
3700		4T-30211	6013	4T-30207	6002(4)	-	6208ZZ

2A: Ball bearing or taper roller bearing (LLU: contact: rubber seal type) 2B, 2F, 2G: Ball bearing (ZZ: metal seal type)

2D: Needle bearing or ball bearing

2E: Taper roller bearing

2F: Shaft washer

Oil seal name number list

Model	Seal position	Output shaft 2R	Input shaft 2S
400		D30458	S25408(2)
750		D35508	S32458(2)
1500		D40588	S38558(2)
2200		D50729	S42659(2)
3700		D55729	S50729(2)

The number of pieces is indicated in brackets. The number of pieces without bracket indication is one.

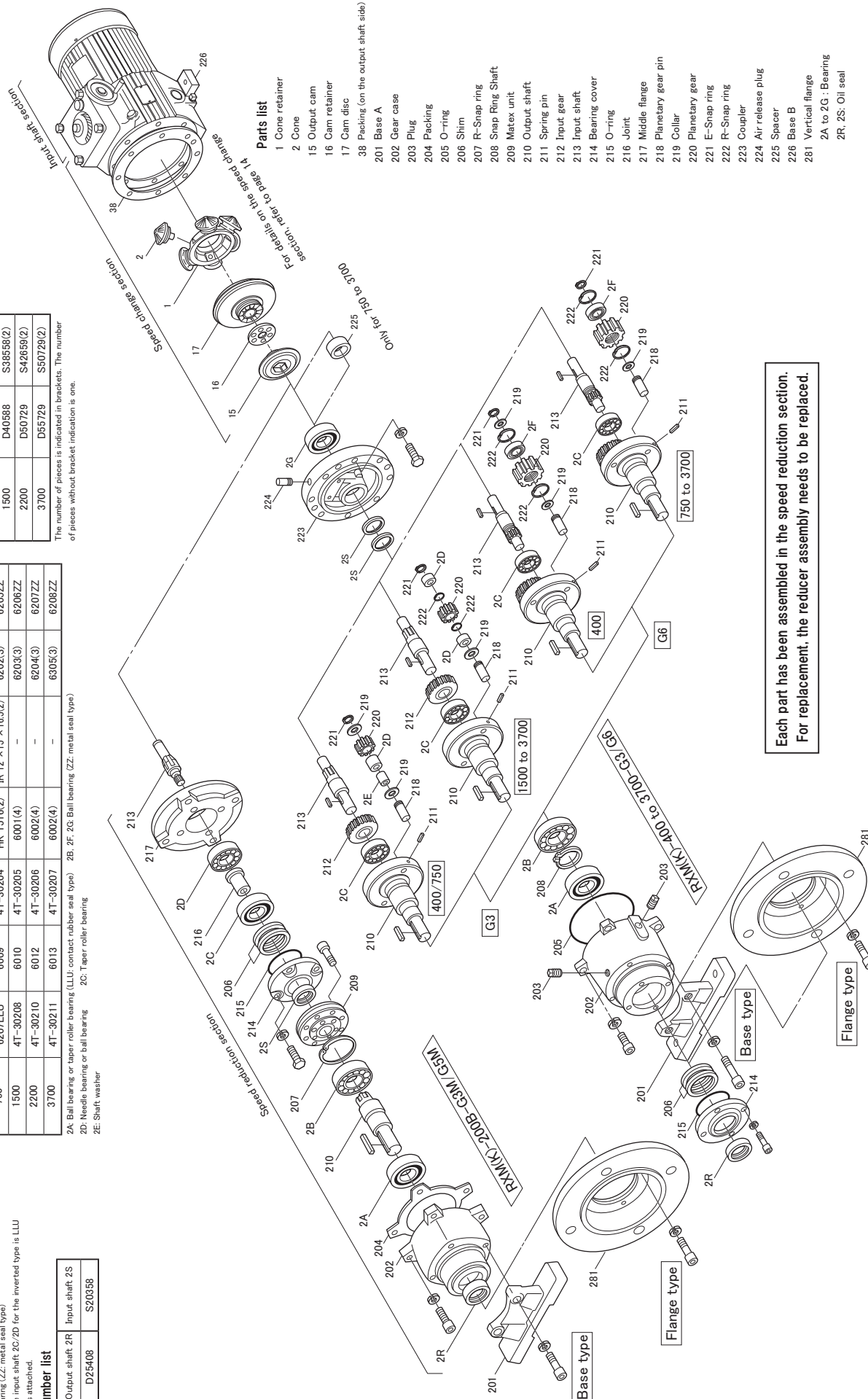

Parts list

- 1 Cone retainer
- 2 Cone
- 15 Output cam
- 16 Cam retainer
- 17 Cam disc
- 38 Packing (on the output shaft side)
- 201 Base A
- 202 Gear case
- 203 Plug
- 204 Packing
- 205 O-ring
- 206 Shim
- 207 R-Snap ring
- 208 Snap Ring Shaft
- 209 Matrex unit
- 210 Output shaft
- 211 Spring pin
- 212 Input gear
- 213 Input shaft
- 214 Bearing cover
- 215 O-ring
- 216 Joint
- 217 Middle flange
- 218 Planetary gear pin
- 219 Collar
- 220 Planetary gear
- 221 E-Snap ring
- 222 R-Snap ring
- 223 Coupler
- 224 Air release plug
- 225 Spacer
- 226 Base B
- 281 Vertical flange
- 2R to 2G : Bearing
- 2R, 2S: Oil seal

Each part has been assembled in the speed reduction section.
For replacement, the reducer assembly needs to be replaced.

Disassembly and reassembly diagram for CORONET reducer section 1

N11 to N71 Frame B, C / RXM (K) -200B to 750-N □ B, N □ C

*For the speed change section, refer to page 14.

Bearing name number list

Frame size	Bearing position	Reduction ratio	Output shaft	Output shaft	Input shaft	Input shaft
			3A	3B	3C	3F
B	N11	630ZZ	6209ZZ	NF 153212	IR 121512	-
	N17,29,35,47,59,71	630ZZ	6209ZZ	NF 153212	-	51204
C	N11	6309ZZ	6212ZZ	NF 2204	IR 172016	51206
	N17,29,35,47,59,71	6309ZZ	6212ZZ	NF 2204	-	51206

3A, 3B, 3E: Ball bearing (ZZ: metal seal type)
 3C: Roller bearing 3F: Thrust bearing 3G: Shaft washer
 RAM(K)-200B

*The bearing type on the input shaft 3E for the inverted type is LLU when the sensor gear is attached.

Bearing name number list

Speed drive model	Bearing position	Input shaft	Input shaft
		3E	3F
200B	6304ZZ	6304ZZ	-
400	6305ZZ	6305ZZ	51204
750	6306ZZ	6306ZZ	51206

Oil seal name number list

Frame size	Seal position	Reduction ratio	Output shaft	Input shaft
			3R	3S
B	N11,17,29,35,47,59,71	D45629	D45629	S26388(2)
C	N11,17,29,35,47,59,71	D55709	D55709	S30438(2)
				S35508(2)

The number of pieces is indicated in brackets. The number of pieces without bracket indication is one.

3A to 3G: Bearing
 3R, 3S: Oil seal

Parts list

- 1 Cone retainer
- 2 Cone
- 15 Output cam
- 16 Cam retainer
- 17 Cam disc
- 38 Packing (on the output shaft side)
- 339 Snap Ring Shaft
- 301 Base
- 306 Output shaft
- 307 Output shaft bush
- 309 Distance collar
- 310 Bush
- 311 Wheel
- 312 Wheel spacer
- 313 Eccentric roller bearing
- 317 Carrier pin
- 319 Internal pin
- 320 Internal pin housing
- 321 ER flange
- 334 Cover
- 335 O-ring
- 336 Adjuster
- 337 Counter Shaft bush
- 338 Input shaft
- 340 Thrust seat
- 370 Packing (on the output shaft side)
- 371 Packing (on the input shaft side)
- 381 Vertical flange
- 383 Stud bolt

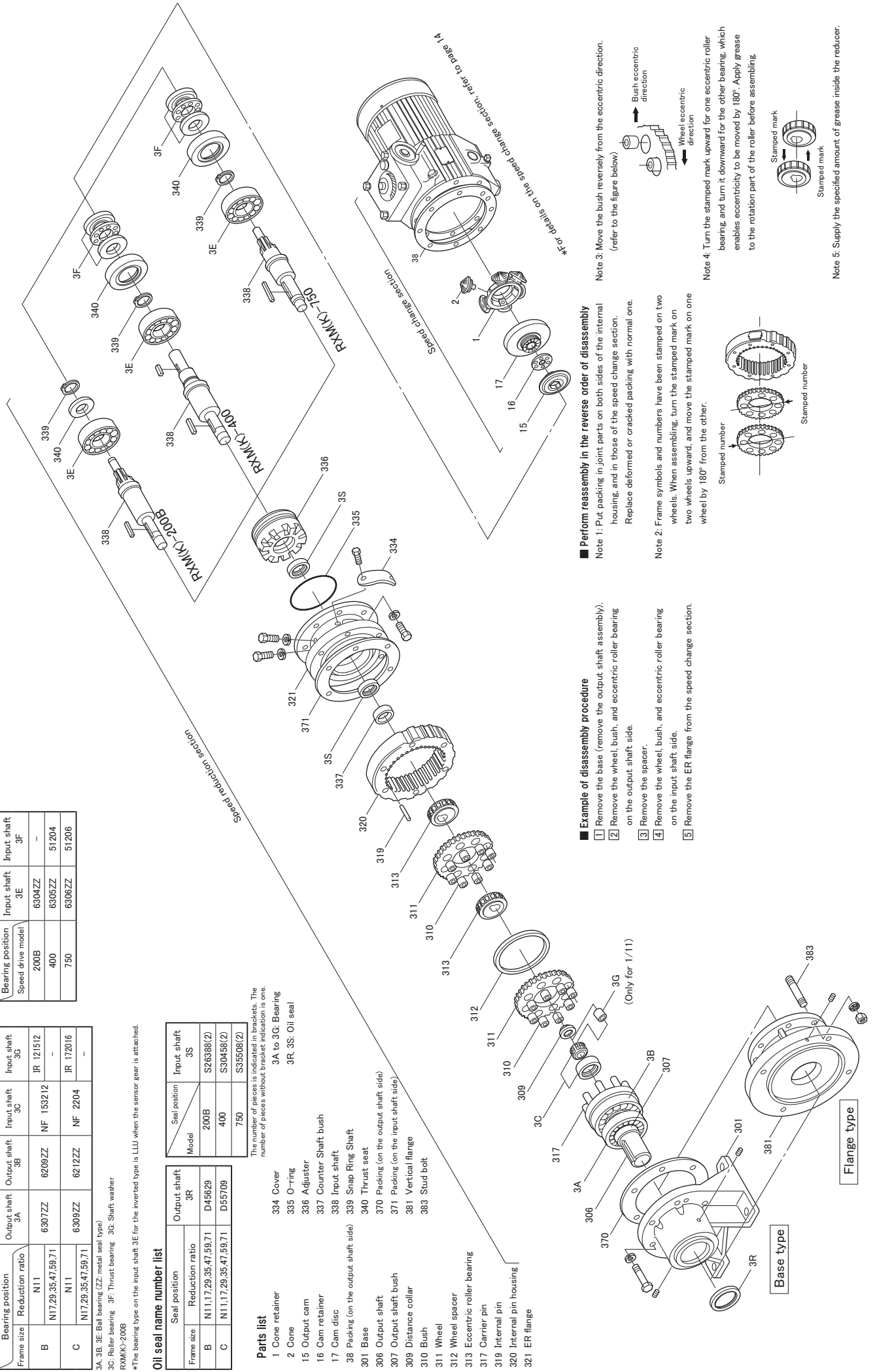

Example of disassembly procedure

- 1 Remove the base (remove the output shaft assembly).
- 2 Remove the wheel, bush, and eccentric roller bearing on the output shaft side.
- 3 Remove the spacer.
- 4 Remove the wheel, bush, and eccentric roller bearing on the input shaft side.
- 5 Remove the ER flange from the speed change section.

Perform reassembly in the reverse order of disassembly

Note 1: Put packing in joint parts on both sides of the internal housing, and in those of the speed change section.
 Replace deformed or cracked packing with normal one.

Note 2: Frame symbols and numbers have been stamped on two wheels upward, and move the stamped mark on one wheel by 180° from the other.

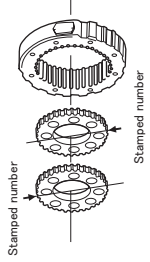

Note 3: Move the bush reversely from the eccentric direction. (refer to the figure below)

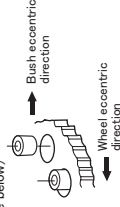

Note 4: Turn the stamped mark upward for one eccentric roller bearing, and turn it downward for the other bearing, which enables eccentricity to be moved by 180°. Apply grease to the rotation part of the roller before assembling.

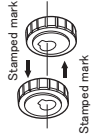

Note 5: Supply the specified amount of grease inside the reducer.

Disassembly and reassembly diagram for CORONET reducer section 2 N11 to N71 Frame D, E, F / RXM (K) -750 to 3700-N□D, N□E, N□F

* For the speed change section, refer to page 14.

Bearing name number list

Bearing position	Input shaft	Input shaft
Speed drive model	3E	3F
750	6306 ZZ	51206
1500	6307 ZZ	51207
2200	6307 ZZ	51307
3700	6309 ZZ	51308

Bearing name number list

Frame size	Reduction ratio	Output shaft	Input shaft
D	N11	6213NR	6010
E	N11	NF 2305	6210
	N11	NF 2305	6015
F	N11.17	NF 2306	6216
	N29.35.47.59.71	NF 2308	

3A, 3D, 3E: Ball bearing (ZZ: metal seal type, NR: with snap ring)
 3C: Roller bearing
 3A: LLU for the inverted type
 3D, ZZ for the vertical type

Oil seal name number list

Seal position	Input shaft
Speed drive model	3S
750	S 35508(2)
1500	S 50659(2)
2200	S 50659(2)
3700	S 55729(2)

The number of pieces is indicated in brackets. The number of pieces without bracket indicates one.

Example of disassembly procedure

- Remove the hexagon socket plug, and drain oil.
- Remove the bearing cover.
- Remove the snap ring of bearing 3A.
- Remove the base.
- Remove the bolt from the carrier pin, and release the output shaft.
- Remove the wheel, bush, and eccentric roller bearing on the output shaft side.
- Remove the spacer.
- Remove the wheel, bush, and eccentric roller bearing on the input shaft side.
- Remove the holder, and remove the ER flange from the speed change section.

Perform reassembly in the reverse order of disassembly

- Note 1: Put packing in joint parts on both sides of the internal housing, and in those of the speed change section. Replace deformed or cracked packing with normal one.
- Note 2: Frame symbols and numbers have been stamped on two wheels. When assembling, turn the stamped mark on two wheels upward, and move the stamped mark on one wheel by 180° from the other.

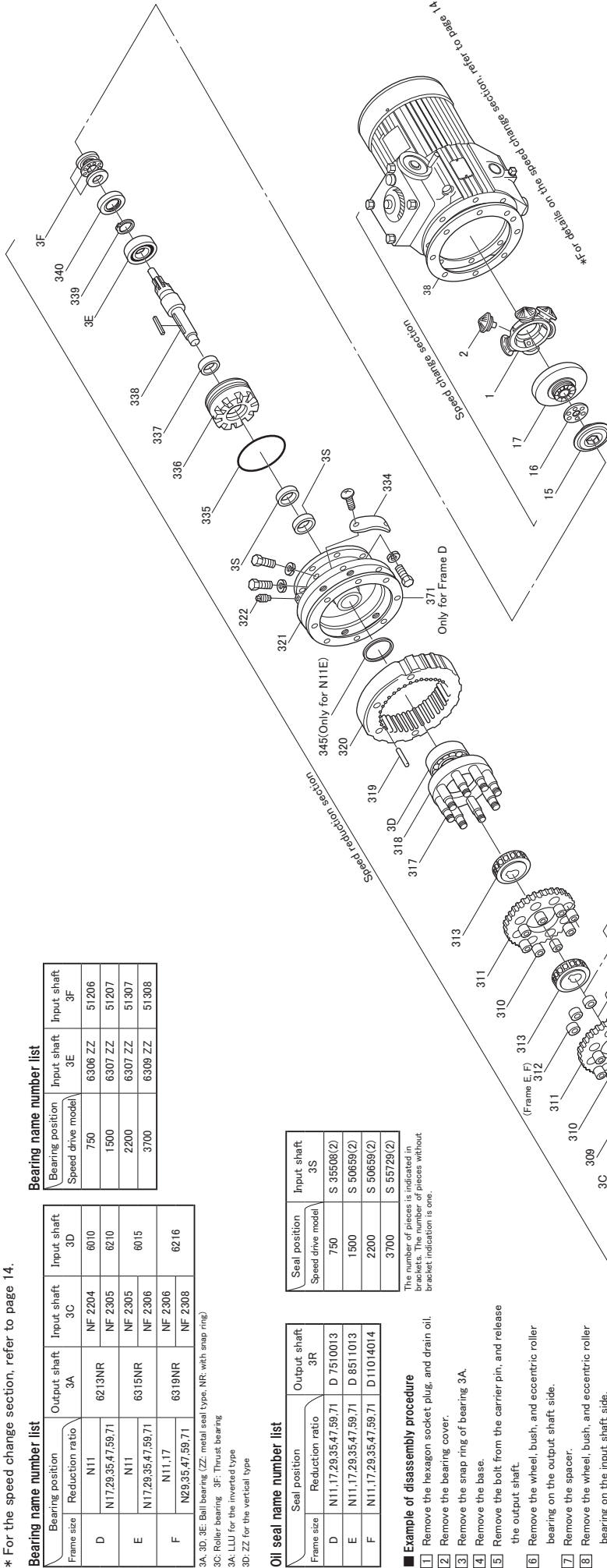
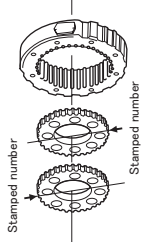

Parts list

- | | |
|---------------------------------------|--|
| 1 Cone retainer | 319 Internal pin |
| 2 Cone | 320 Internal pin housing |
| 15 Output cam | 321 ER flange |
| 16 Cam retainer | 322 Plug |
| 17 Cam disc | 334 Cover |
| 38 Packing (on the output shaft side) | 335 O-ring |
| 301 Base | 336 Adjuster |
| 302 Bearing cover | 337 Counter shaft bush |
| 303 Snap ring | 338 Input shaft |
| 304 Spring pin | 339 Snap Ring Shaft |
| 305 Hexagon socket plug | 340 Thrust seat |
| 306 Output shaft | 345 Spacer |
| 307 Output shaft bush | 370 Packing (on the output shaft side) |
| 308 Positioning spacer | 371 Packing (on the input shaft side) |
| 309 Distance collar | 372 Packing (bearing cover part) |
| 310 Bush | 381 Vertical flange |
| 311 Wheel | 382 Spring pin |
| 312 Wheel spacer | 383 Stud bolt |
| 313 Eccentric roller bearing | 3A to 3F: Bearing |
| 317 Carrier pin | 3R, 3S: Oil seal |
| 318 Holder | |

Note 3: Move the bush reversely from the eccentric direction, (refer to the figure below)



Note 4: Turn the stamped mark upward for one eccentric roller bearing, and turn it downward for the other bearing, which enables eccentricity to be moved by 180°. Apply grease to the rotation part of the roller before assembling.

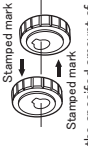

Note 5: Supply the specified amount of oil inside the reducer.

Flange type

Base type

Disassembly and reassembly diagram for inscribed planetary reducer section

3 C11 to C87 Frame H, L RXMK-5500 to 7500-C□H, C□L

* For the speed change section, refer to page 16.

Bearing name number list

Bearing position	Flange section		Speed reduction section	
	(14)	(16)	(5)	(7)
Frame size and reduction ratio	6312	6312ZZ	6408	6408
H C11.21.29.43.87	6312	6312ZZ	6408	6408
L C11.21.29.43.87	6312	6312	6408	6408

The number of pieces is indicated in brackets. The number of pieces without bracket indication is one.

Seal position	Speed reduction section	
	(20)	(16)
Frame size and reduction ratio	S8010513(2)	D12015516
H C11.21.29.43.87	S8010513(2)	D12015516
L C11.21.29.43.87	S8010513(2)	D16019016

Example of disassembly procedure

Place the speed reduction section down, remove upper bolts, and separate the low speed section.

Disassembly procedure for the speed reduction section

Inner roller (16) Wheel (17) Spacer ring (18) Snap Ring Shaft (1) Bearing (2) Distance piece B (3) End bracket (4) Eccentric Roller Bearing (5) (with bearing (5)) Curve disc (6) End bracket (4) Size (10) Outer pin (11) Outer roller (12)

Disassembly procedure for the low speed section

Cover (Gland) (17) Snap ring shaft for bearing (7) Low speed shaft (6) (with (7)(8)(18))

Perform reassembly in the reverse order of disassembly

Note 1: Frame symbols and numbers have been stamped on two wheels.

When assembling, turn the stamped mark on two wheels up, and move the stamped mark on one wheel by 180° from the other.

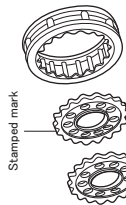

Stamped mark

Note 2: Place both stamped surfaces outward, respectively, and assemble into the Eccentric Roller Bearing (2).

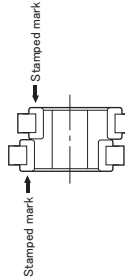

Note 3: Worn or damaged oil seals, collars, and/or packing, etc. could result in oil leakage. Be sure to replace them with new ones.

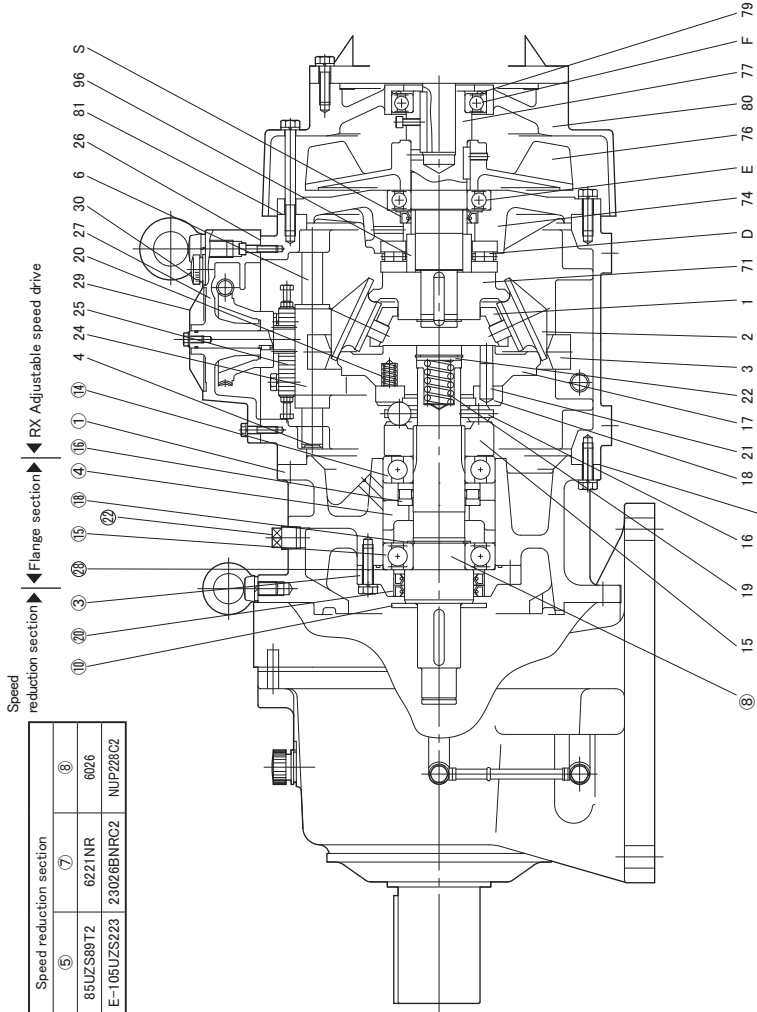

Parts list

Speed change section

- 1 Cone retainer
- 2 Cone
- 3 Ring
- 4 Rubber packing
- 6 Guide shaft
- 15 Output cam
- 16 Cam retainer
- 17 Cam disc
- 18 Input cam
- 19 Auxiliary spring
- 20 Spring
- 21 Needle roller
- 22 Spring seat
- 24 Rack gear holder
- 25 Rack gear
- 26 Cover packing
- 27 Cover
- 29 Dial Plate
- 30 Breather cap
- 38 Packing (on the output shaft side)
- 71 Input disc
- 74 Input shaft holder
- 76 Fan
- 77 Motor shaft

Flange section

- 1 Flange
- 3 Bearing cover
- 4 Collar
- 8 Counter Shaft
- 10 End bracket
- 14 Ball bearing
- 15 Ball bearing
- 16 Thrust roller bearing
- 18 Snap Ring Shaft
- 20 Oil seal
- 22 Plug
- 26 Shim

Parts list

- 1 Snap Ring Shaft
- 2 Bearing
- 3 Distance piece B
- 4 End bracket
- 5 Bearing
- 6 Low speed shaft
- 7 Bearing
- 8 Bearing
- 10 Inner pin
- 11 Packing
- 12 Packing
- 16 Oil seal
- 17 Gland
- 18 Collar
- 23 Plug
- 29 Upper bolt
- 30 Packing
- 31 Frame
- 32 Eccentric Roller Bearing
- 33 Wheels
- 34 Outer pin
- 35 Spacer ring
- 36 Inner roller

Speed reduction section (vertical type)

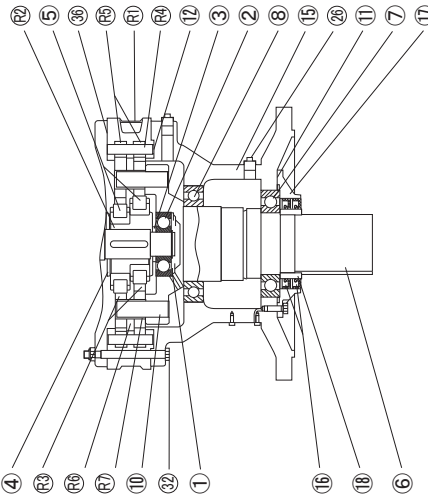

Parts list

- 1 Snap Ring Shaft
- 2 Bearing
- 3 Distance piece B
- 4 End bracket
- 5 Bearing
- 6 Low speed shaft
- 7 Bearing
- 8 Snap Ring Shaft
- 10 Inner pin
- 11 Packing
- 12 Packing
- 15 Outer side cover
- 16 Oil seal
- 17 Cover
- 18 Collar
- 22 Oil filling plug
- 23 Upper bolt
- 24 Packing
- 25 Frame
- 26 Eccentric Roller Bearing
- 27 Wheels
- 30 Outer pin
- 31 Outer roller
- 32 Spacer ring
- 33 Inner roller

Speed reduction section (horizontal type)

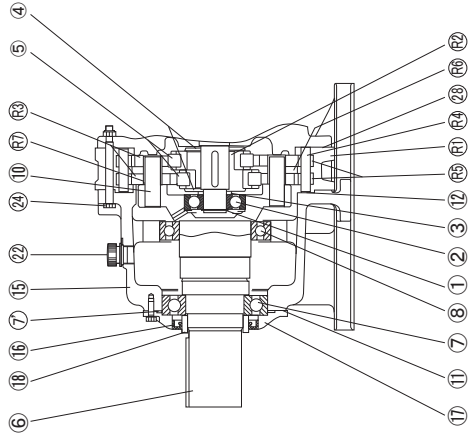

Disassembly and reassembly diagram for automatic control specifications speed change section

RXM (K) R-200B to 7500

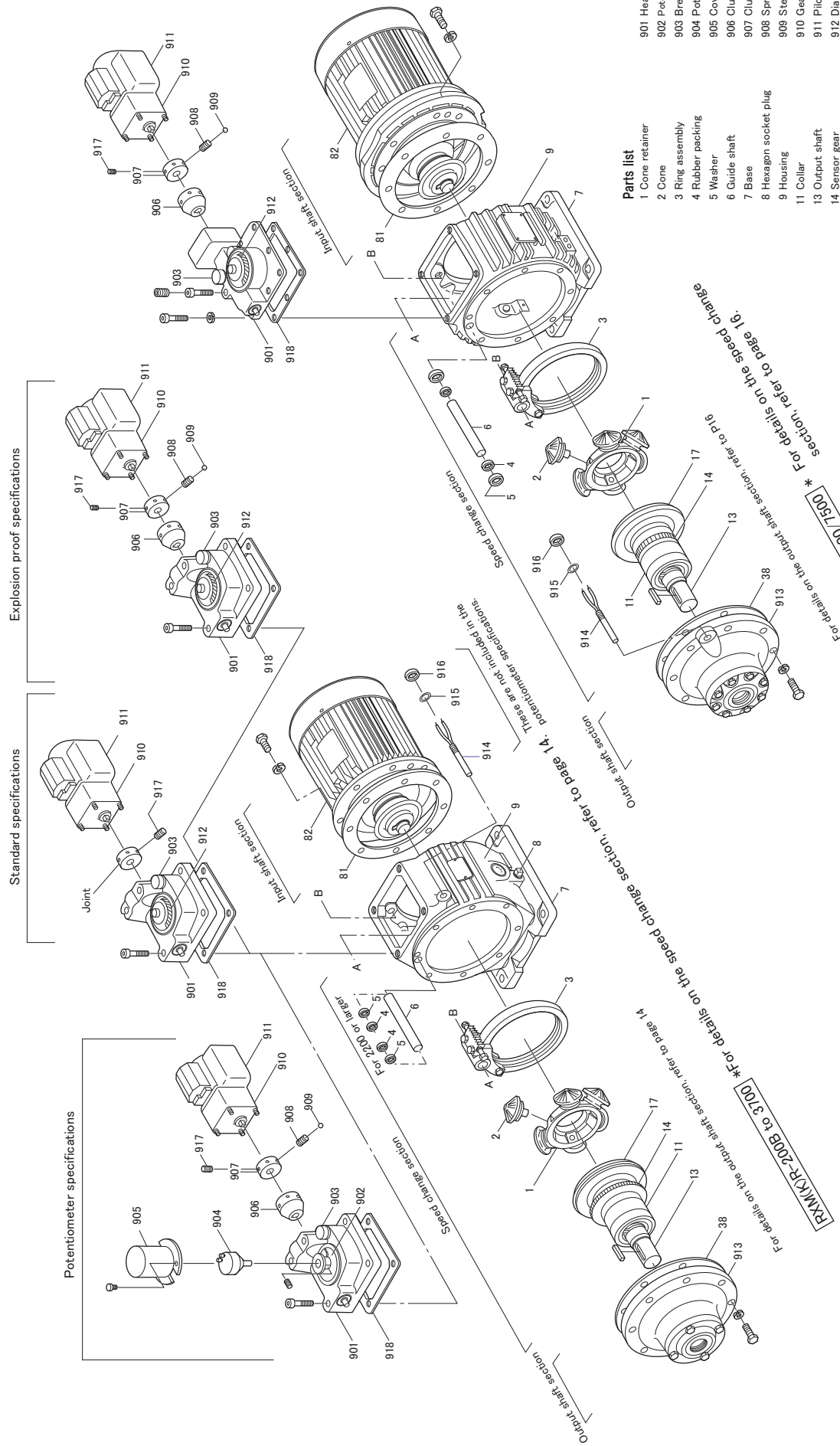

Parts list

- 1 Cone retainer
- 2 Cone
- 3 Ring assembly
- 4 Rubber packing
- 5 Washer
- 6 Guide shaft
- 7 Base
- 8 Hexagon socket plug
- 9 Housing
- 10 Collar
- 11 Output shaft
- 13 Sensor gear
- 14 Dial Plate
- 17 Cam disc
- 38 Packing (on the output shaft side)
- 82 Motor
- 81 Packing (on the input shaft side)
- 916 Round nut
- 917 Set bolt
- 918 Packing (head cover part)

NIDEC DRIVE TECHNOLOGY CORPORATION

〈Web Page Information〉 Please scan the QR code or access the URL below.



Contact Us

<https://www.nidec.com/en/nidec-drivetechnology/inquiry/>



Sales Offices

<https://www.nidec.com/en/nidec-drivetechnology/corporate/network/sales/>

Copyright NIDEC DRIVE TECHNOLOGY Corporation. All Rights Reserved.

NIDEC DRIVE TECHNOLOGY CORPORATION

Nidec Shimpo Corporation change its company name to Nidec Drive Technology Corporation on April 1, 2023.